

Zimmerman®

Ergonomic Handling Systems

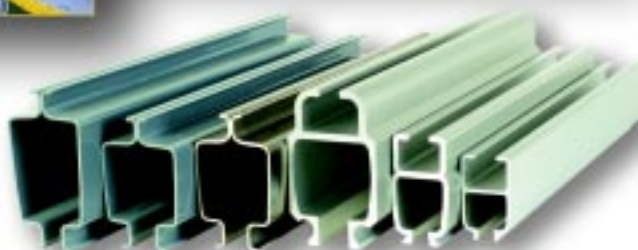

IR Ingersoll Rand®

Ergonomic Handling Systems



Engineered for the Interaction of Man and Machine

We at IR Zimmerman pioneered the development of pneumatic powered lifting and balancing equipment, making us the world leader in the manufacturing of ergonomic, in-process, manual assist, pick, and place systems.

The combination of IR Zimmerman's 40 years of manufacturing excellence, ISO 9001 certification and 24 hour service network has created a unique ability to respond to your needs anywhere in the world with the highest quality material handling equipment available.

With a solid commitment to research and development, we have applied our expertise to introduce new products with technology that is state of the art and most sophisticated in the world. Our most recent innovations are the Intelift pneumatic balancers and intelligent handling devices.

For over 40 years, we have been serving the material handling needs of automotive, appliance, aerospace, converting, electronics, food, furniture, glass, packaging, printing, pharmaceutical, sheet metal, textile and warehousing industries worldwide.

In the following pages we present all of our material handling products with several illustrations and descriptions of product features.



Application pictures of IR Zimmerman Material Handling System in the automotive industry.

**Call 1-800-347-7047
for distributors in your area**



Experts in the development of solutions and components for the ergonomic handling of products



*IR Zimmerman Intelligent Lifting Systems:
Shown here in a vehicle assembly industry application.*









*IR Zimmerman Enclosed Track Rail
System:
Shown here in an automotive industry application.*



E.A.S.E. Ergonomic Assist
Systems and Equipment
A Product Council of Material Handling Industry

Table of Contents



	<u>Rail Systems</u>	<u>1-5</u>
	<u>Jib Cranes</u>	<u>6-9</u>
	<u>Intelift Pneumatic Balancers</u>	<u>10-16</u>
	<u>Balancers</u>	<u>17-24</u>
	<u>Arm Systems</u>	<u>25-34</u>
	<u>Handling Devices</u>	<u>35-39</u>
	<u>Torque Reaction Products</u>	<u>40-50</u>
	<u>Irax Spring Balancers</u>	<u>51-57</u>
	<u>Quantum Electric Chain Hoists</u>	<u>58-64</u>

Ingersoll-Rand Tool and Hoist Division

Headquartered in Annandale, New Jersey, offers the broadest range of ergonomic material handling systems in the world. Ingersoll-Rand is committed to fulfill our customers' expectations by providing products, technology and services of the highest quality. Constantly, we strive for world class standards in customer service and foster the involvement and dedication of our employees to continuing improvement. Our systems are sold and serviced by a network of distributors around the world. We appreciate the opportunity to meet your material handling product needs.

The new  **Ingersoll-Rand** corporate brand identity introduction in 2000, is now being incorporated into product identification and packaging, as well as all communication. While all product photography in this catalog reflects the new symbol and logo type signature, many of our products are still in the process of being updated to reflect our new look on everything IR.



The Backbone of Material Handling Technology

Engineered for the Interaction of Man and Machine.

Backbone to build on

Through a solid commitment to research and development, we have applied our expertise to produce the most complete line of enclosed track workstation crane and monorail systems from one manufacturer in the world. Available in aluminum, steel, and stainless steel, these overhead conveyance rails form the backbone for any material handling system.

The IR Zimmerman Rail Systems advantage

- **Lightweight and Ergonomic:** Less than 1% rolling resistance
- **Precision Running Surface:** Aluminum, steel, and stainless steel available
- **Modular and Flexible:** Bolted together; no welding required
- **Clean, Maintenance-free Operation:** No lubrication required
- **Safety:** Designed to meet or exceed all national and international standards

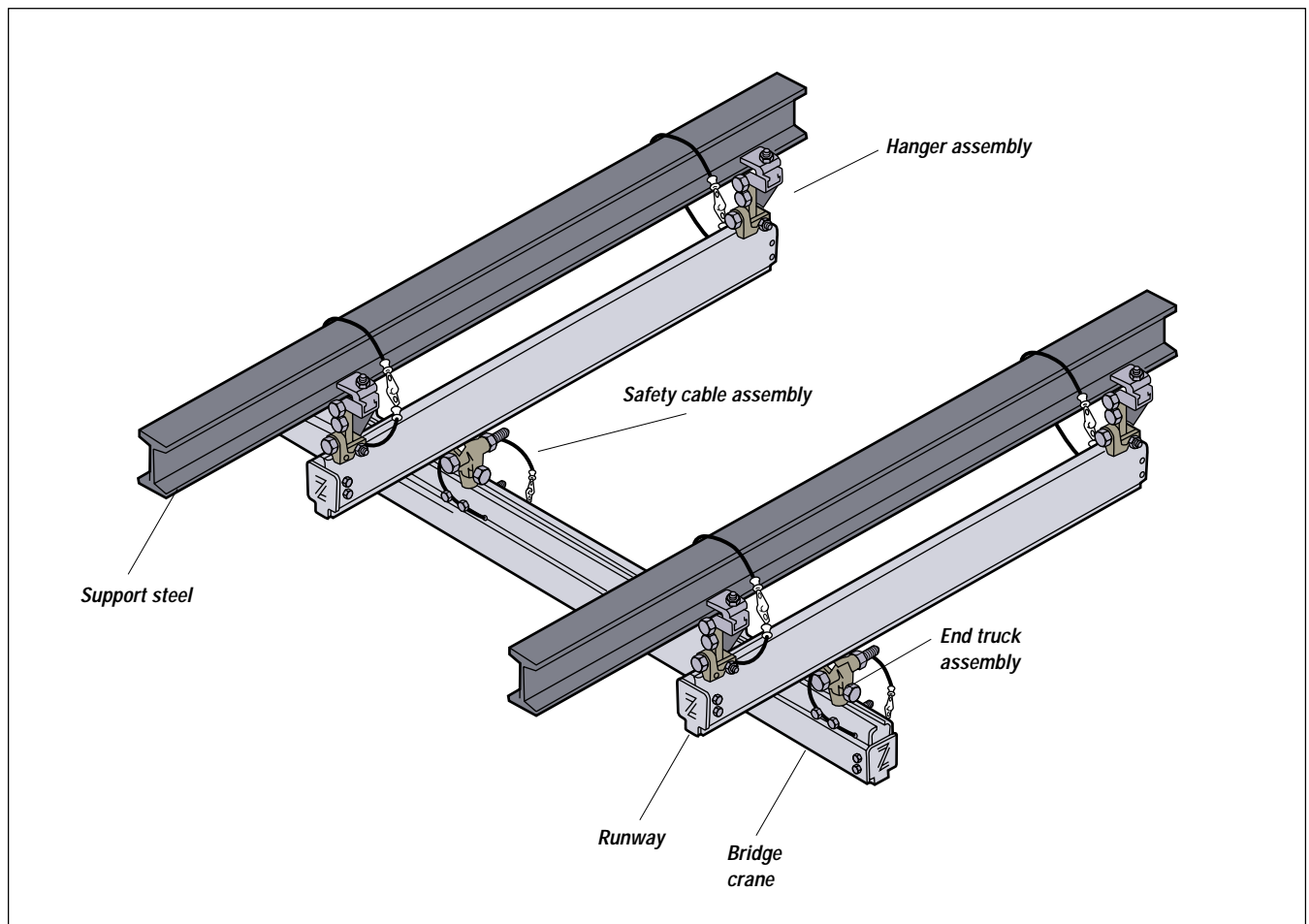

Rail Systems



Quality Steel, Aluminum and Stainless Steel Rail Systems

IR Zimmerman rails are available in three different materials and five different sizes to meet your specific material handling needs. The Enclosed Rail Systems design reduces the accumulation of dirt and grime on the internal rolling surfaces, thus reducing rolling effort.

Aluminum

Lightweight and available for long spans

- **Extruded:** From aluminum alloy 6063-T6
- **Clear Anodized:** For a smooth, clean, corrosive-free surface
- **ZRAT:** Available in lengths up to 24 feet (7 meters)
- **ZRA1:** Available in lengths up to 30 feet (9 meters)
- **ZRA2:** Available in lengths up to 30 feet (9 meters)
- **Strongbacking:** Available for increased capacities

Steel

The strong, economical choice, ideal for heavy weight applications

- **Roll Formed:** From 9 gauge, A569 hot-rolled steel
- **Spot Welded:** With automated welder for maximum strength
- **Powder Coat Painted:** For durability and smoothness
- **ZRS2:** Available in lengths up to 24 feet (7 meters)
- **ZRS3:** Available in lengths up to 24 feet (7 meters)
- **Strongbacking:** Available for increased capacities

Stainless Steel

Engineered for cleanroom applications, ideal for the food and pharmaceutical industries

- **Roll Formed:** From 10 gauge, 316L stainless steel
- **Spot Welded:** With automated welder for maximum strength
- **ZRSS:** Available in lengths up to 24 feet (7 meters)

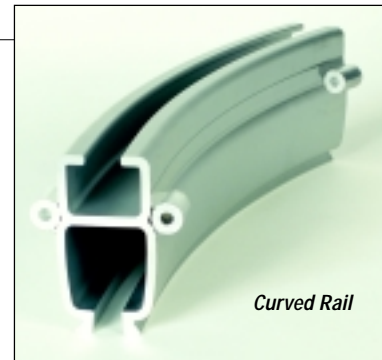
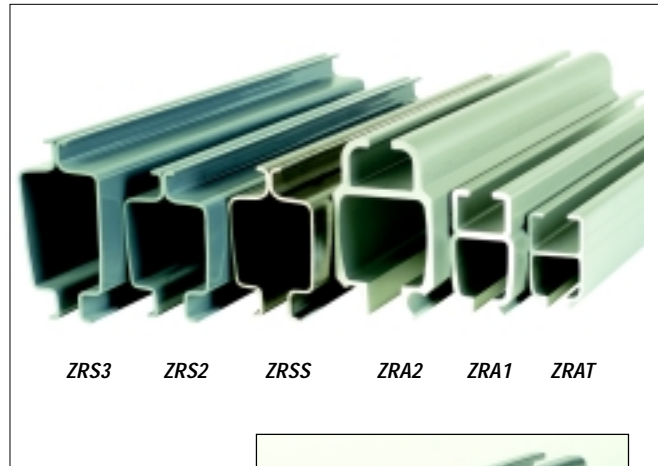

IR Zimmerman rail system application shown in a manufacturing facility.

Safety First

IR Zimmerman's primary and vital concern is safety.

- **Deflection:** IR Zimmerman rail is designed to not exceed 1/450 of span, in accordance with ANSI B30.11 Monorail and Underhung Cranes.
- **Safety Cables:** We require the use of safety cables at all moving (hanger and end-truck) suspension points.
- **Redundant End Stops:** Available for extra safety.
- **Load Ratings:** Clearly marked on both sides of bridge rails.
- **Safety Factor:** All hardware components are rated at a 5 to 1 safety factor based on meticulous tests performed at independent testing laboratories.

Hangers

We offer a wide variety of hangers to attach to virtually any type of overhead steel. Available in either rigid (anti-compression) or pivoting styles to match the material handling operation, the hangers are available in fixed and adjustable lengths for all rails. For extra safety, We require that all hangers with a drop of 24 inches or greater have sway/thrust bracing for stability.

End Trucks

While we offer both articulating and rigid end trucks to match the material handling application, the primary system sold utilizes the articulating end truck. This feature maximizes the ability of the operator to precisely position loads by allowing them to move only the portion of the bridge crane near the load. This results in dramatic improvements over typical rigid end truck systems which require the user to move the entire mass of the bridge crane for each operation.

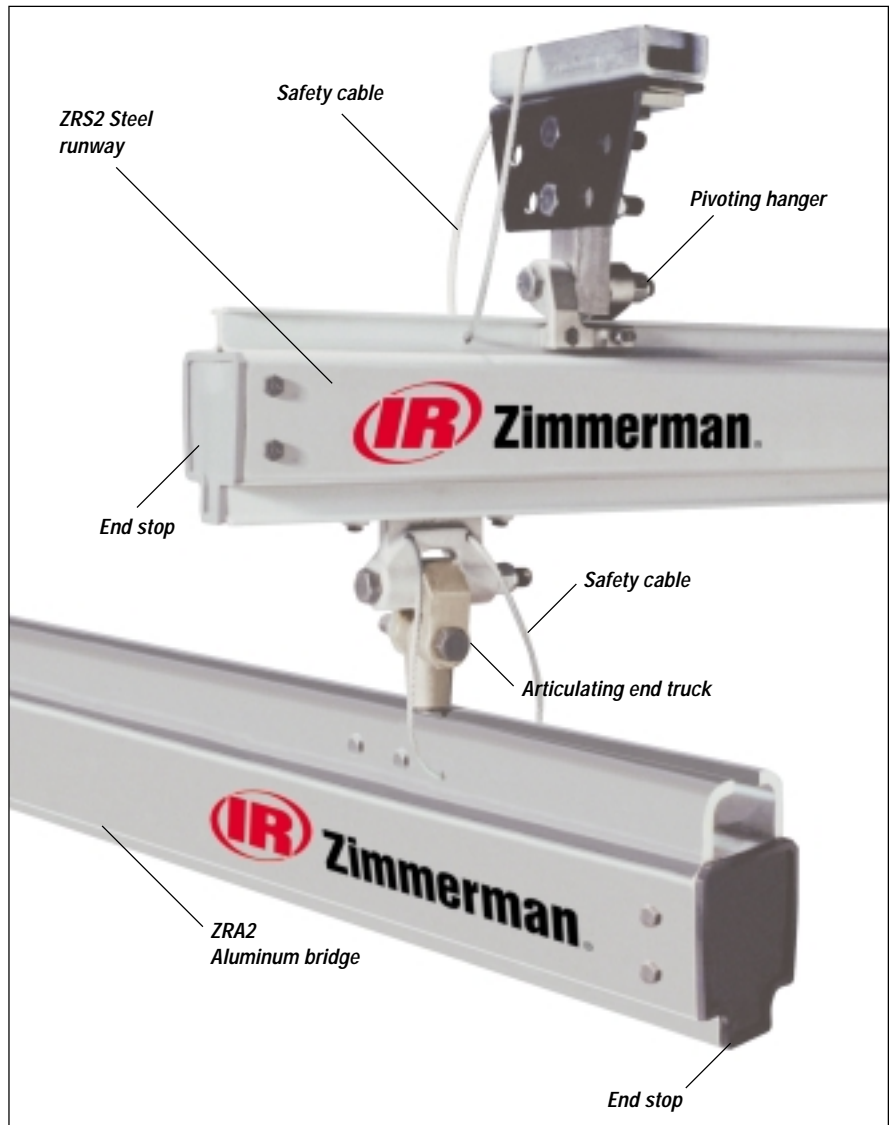

Adjustable hanger shown with steel rail

IR Zimmerman helps build a Deere

Overhead articulating bridge crane system from IR Zimmerman being used in a John Deere™ manufacturing facility.



Courtesy of Modern Material Handling Magazine.

Advanced Trolley Design

IR Zimmerman trolleys are designed to work in conjunction with the Enclosed Track Rail to reduce the rolling effort required to move a load. In fact, only a force equal to one percent of the total rolling weight is needed when moving loads.

- **Lightweight:** Trolleys are primarily made from high-strength Almag castings. Also available in steel and stainless steel stampings.
- **Injection Molded Wheels:** Provide for clean, wear-free operation that resists flattening.
- **Sealed Precision Bearings:** In wheels and side guide rollers, they provide long life and reduced maintenance.
- **Rail Safety Lug:** Prevents the body of the trolley from being pulled through the enclosed track rail.
- **Versatile:** Zimmerman-built trolleys are available for use in virtually every manufacturer's enclosed track rail system.



IR Zimmerman bridge and runway system in a manufacturing plant.

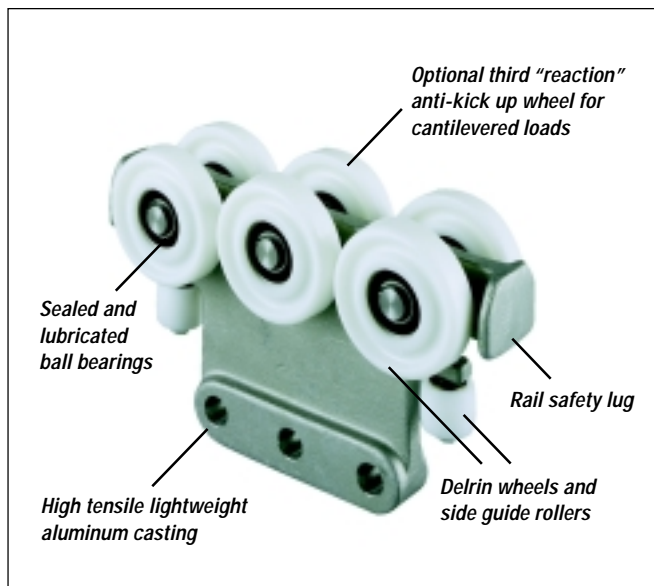

Free Standing Workstation and Crane Systems

Zimmerman offers both standard and custom free standing floor supported systems. These systems allow for the placement of workstation rail systems independent of existing overhead structural steel.



Power Supply

Air supply: Kits are available in both 3/8" and 1/2". Kits are available with a filter/regulator for use with Balancers and manipulator systems. We also supply air supply kits without the filter/regulator for use with oil-based pneumatic systems such as hoists and tractor drives.

Electrical supply: Kits are available to supplement virtually any type of electrical equipment. Insul-8 electrification systems are available.



Air supply festooning using pre coil tube assembly



Electric supply using Insul-8

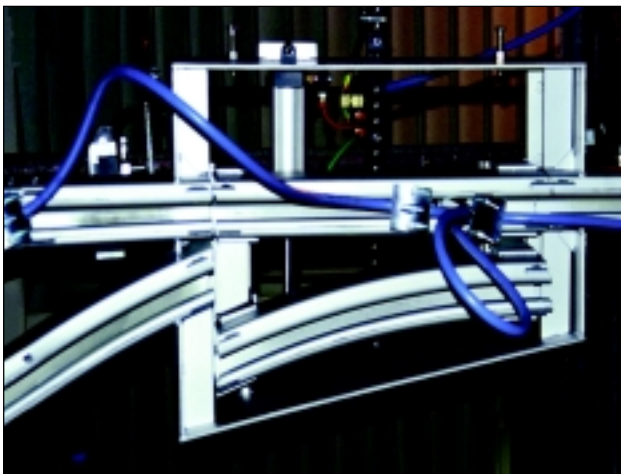

Accessories

A wide range of accessories such as curved rail, track switches, bridge extensions, and custom designed components are available to enhance any crane or monorail system.

Powered track switch for use in monorail applications

Air Supply Assembly

Keeps coil hose and electrical supply in place. Allows complete utilization of the bridge and runway system. Filter Regulator provides clean regulated air.

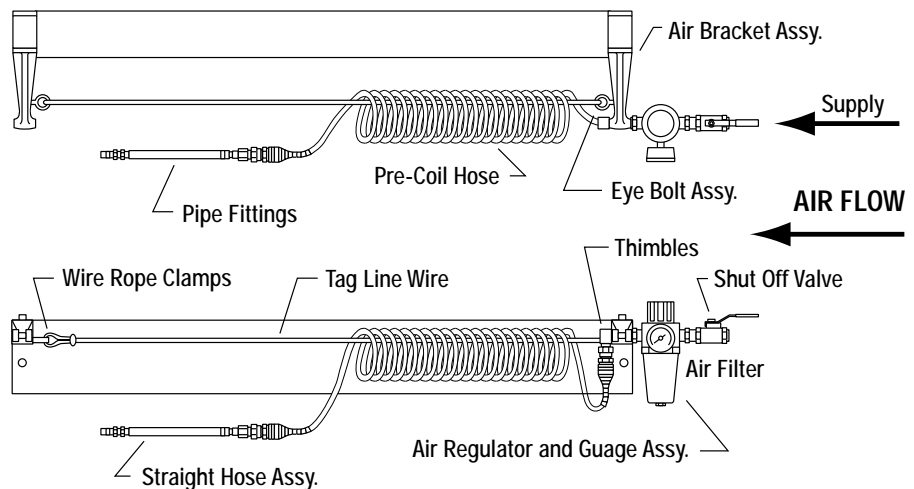

IR Zimmerman Jib Cranes

- *Ergonomic:* Light-duty jib cranes utilize precision IR Zimmerman aluminum or steel rail for the boom, resulting in a lightweight, easy to move boom.
- *Cost Effective:* Jib cranes are perfect for short transfer applications.

Available in the following configurations

- *700J:* 220 degree rotation, tie-rod based jib crane with column for floor or ceiling mounting.
- *700JW:* 220 degree rotation, tie-rod based jib crane with plate for mounting to walls, existing building columns, or any suitable surface.
- *800J:* 360 degree rotation, tie-rod based jib crane with column for floor mounting.

Options

IR Zimmerman jib cranes can be ordered with either air or electric power supply packages. They are also available with portable pallet base mounts.

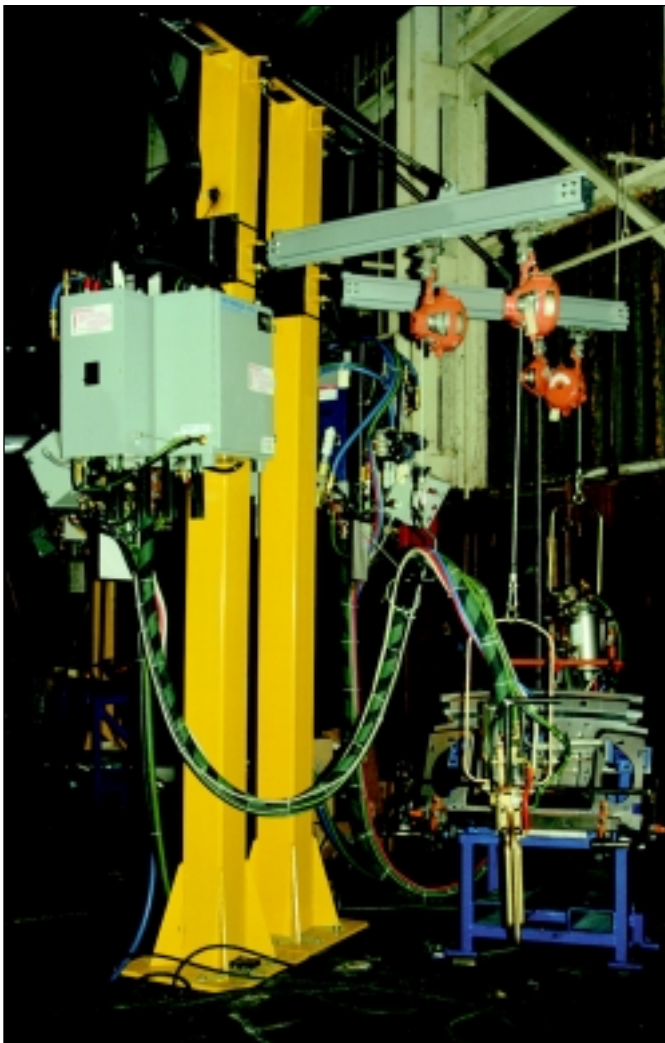

700J Jib Crane

Custom Jibs Offered

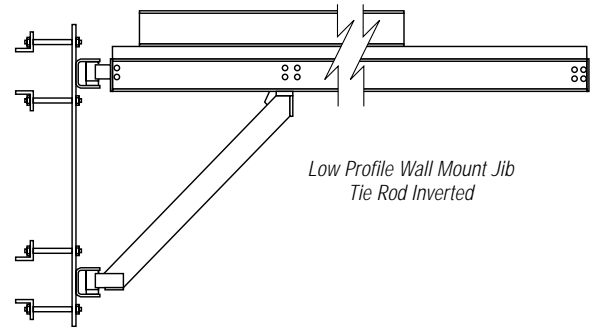

Low Profile Wall Mount Jib
Tie Rod Inverted

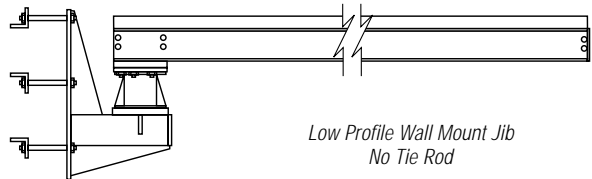

Low Profile Wall Mount Jib
No Tie Rod

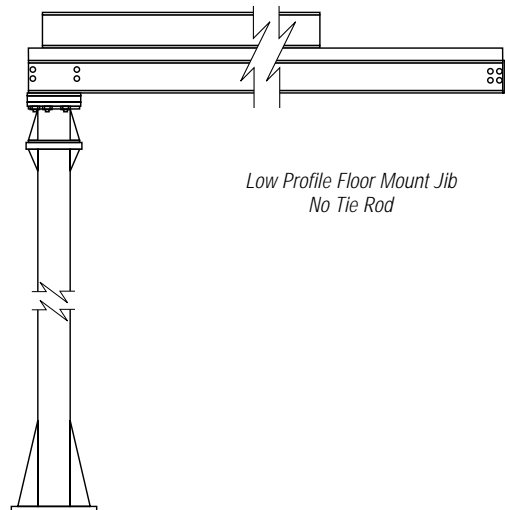

Low Profile Floor Mount Jib
No Tie Rod

ZRA1 Boom Type 220° Rotation (Light)

Part no.	Boom		Capacity		OAH = U +		Weight	
	ft	m	lbs	kg	in.	mm	lbs	kg
7090JA1F04144	4	1.22	900	408.2	38	965	375	170.5
7061JA1F06144	6	1.83	610	276.7	38	965	375	174.1
7046JA1F08144	8	2.44	460	208.7	38	965	391	177.7
7037JA1F10144	10	3.05	370	167.8	38	965	399	181.4
7030JA1F12144	12	3.66	300	136.1	38	965	407	185
7026JA1F14144	14	4.27	260	117.9	38	965	414	188.2
7023JA1F16144	16	4.88	230	104.3	38	965	423	192.3
7020JA1F18144	18	5.49	200	90.7	38	965	431	195.9
7016JA1F20144	20	6.1	160	72.6	38	965	439	199.5

ZRA2 Boom Type 220° Rotation (Medium)

Part no.	Boom		Capacity		OAH = U +		Weight	
	ft	m	lbs	kg	in.	mm	lbs	kg
7200JA2F04144	4	1.22	2000	907.2	39	991	660	300
7140JA2F06144	6	1.83	1400	635	39	991	675	306.8
7105JA2F08144	8	2.44	1050	476.3	39	991	690	313.6
7080JA2F10144	10	3.05	800	362.9	39	991	705	320.5
7070JA2F12144	12	3.66	700	317.5	39	991	720	327.3
7060JA2F14144	14	4.27	600	272.2	39	991	735	334.1
7050JA2F16144	16	4.88	500	226.8	39	991	782	355.5
7045JA2F18144	18	5.49	450	204.1	39	991	797	362.3
7040JA2F20144	20	6.1	400	181.4	39	991	812	369.1

ZRA2 Boom Type 220° Rotation (Heavy)

Part no.	Boom		Capacity		OAH = U +		Weight	
	ft	m	lbs	kg	in.	mm	lbs	kg
7200JA2F06144	6	1.83	2000	907.2	39	991	925	420.5
7200JA2F08144	8	2.44	2000	907.2	39	991	940	427.3
7160JA2F10144	10	3.05	1600	725.7	39	991	955	434.1
7135JA2F12144	12	3.66	1350	612.3	39	991	970	441
7115JA2F14144	14	4.27	1150	521.6	39	991	985	447.7
7100JA2F16144	16	4.88	1000	453.6	51	1295	1000	454.5
7080JA2F18144	18	5.49	800	362.9	51	1295	1065	484.1
7065JA2F20144	20	6.1	650	294.8	51	1295	1080	491

ZRS2 Boom Type 220° Rotation (Medium)

Part no.	Boom		Capacity		OAH = U +		Weight	
	ft	m	lbs	kg	in.	mm	lbs	kg
7200JS2F04144	4	1.22	2000	907.2	39	961	660	300
7140JS2F06144	6	1.83	1400	635	39	961	675	306.8
7105JS2F08144	8	2.44	1050	476.3	39	961	690	313.6
7085JS2F10144	10	3.05	850	385.6	39	961	705	320.5
7070JS2F12144	12	3.66	700	317.5	39	961	720	327.3
7060JS2F14144	14	4.27	600	272.2	39	961	735	334.1
7053JS2F16144	16	4.88	530	240.4	39	961	782	355.5
7048JS2F18144	18	5.49	480	217.7	39	961	797	362.3
7042JS2F20144	20	6.1	420	190.5	39	961	812	369.1

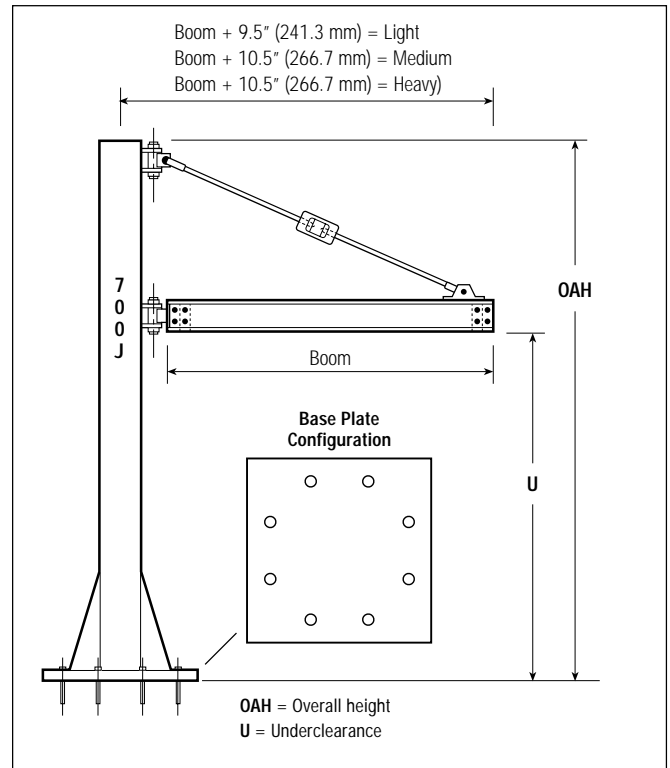

ZRS3 Boom Type 220° Rotation (Heavy)

Part no.	Boom		Capacity		OAH = U +		Weight	
	ft	m	lbs	kg	in.	mm	lbs	kg
7200JS3F04144	4	1.22	2000	907.2	40	1016	910	413.6
7200JS3F06144	6	1.83	2000	907.2	40	1016	927	421.4
7200JS3F08144	8	2.44	2000	907.2	40	1016	944	429.1
7160JS3F10144	10	3.05	1600	725.7	40	1016	961	436.8
7135JS3F12144	12	3.66	1350	612.3	40	1016	978	444.5
7115JS3F14144	14	4.27	1150	521.6	40	1016	995	452.3
7100JS3F16144	16	4.88	1000	453.6	52	1321	1062	482.7
7080JS3F18144	18	5.49	800	362.9	52	1321	1079	490.5
7060JS3F20144	20	6.1	600	272.2	52	1321	1096	498.2

For applications not covered on this sheet or pallet based applications, consult the factory.

Dimensional Notes:

ZRA1 (Light)

U* Standard columns 6 x 6 x 1/4 in. designed for 144 in. (12 ft/3.7 m) under clearance or less.

P Base plate 3/4 x 18 x 18 in., 8-holes 7/8 in. diameter on a 16 in. (406.4 mm) bolt circle.

3/4 in. stud anchors or bolts are to be supplied by the customer.

ZRA2 (Medium)

U* Standard columns 8 x 8 x 1/4 in. designed for 144 in. (12 ft/3.7 m) under clearance or less.

P Base plate 3/4 x 24 x 24 in., 8-holes 7/8 in. diameter on a 20 in. (508 mm) bolt circle.

3/4 in. stud anchors or bolts are to be supplied by the customer.

ZRA2 (Heavy)

U* Standard columns 8 x 8 x 1/2 in. designed for 144 in. (12 ft/3.7 m) under clearance or less.

P Base plate 3/4 x 24 x 24 in., 8-holes 7/8 in. diameter on a 20 in. (508 mm) bolt circle.

3/4 in. stud anchors or bolts are to be supplied by the customer.

ZRS2 (Medium)

U* Standard columns 8 x 8 x 1/4 in. designed for 144 in. (508 mm) under clearance or less.

P Base plate 3/4 x 24 x 24 in., 8-holes 7/8 in. diameter on a 20 in. (508 mm) bolt circle.

3/4 in. stud anchors or bolts are to be supplied by the customer.

ZRS3 (Heavy)

U* Standard columns 8 x 8 x 1/2 in. designed for 144 in. (508 mm) under clearance or less.

P Base plate 3/4 x 24 x 24 in., 8-holes 7/8 in. diameter on a 20 in. (508 mm) bolt circle.

3/4 in. stud anchors or bolts are to be supplied by the customer.

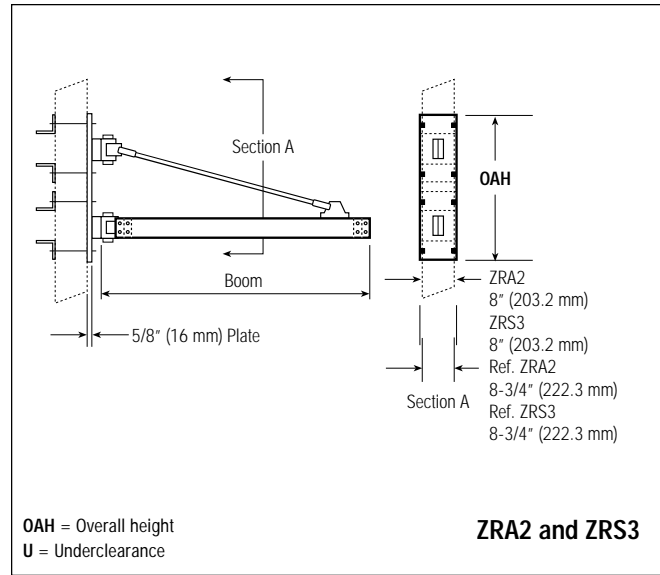
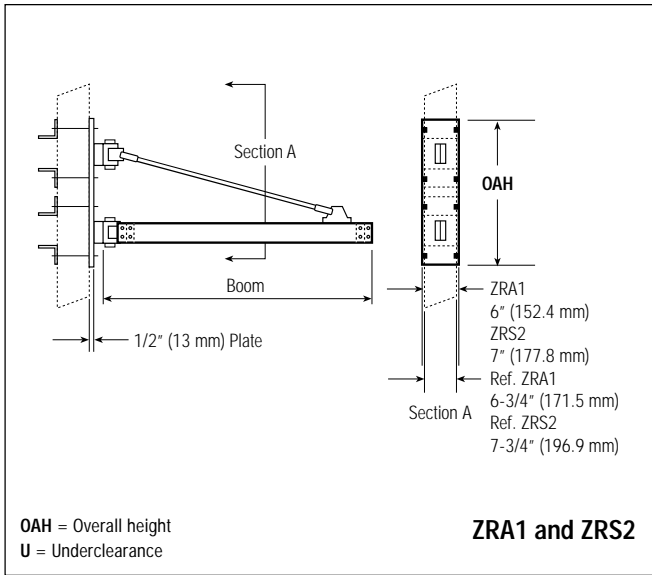

ZRA1 Boom Type Wall Mount (Light)								
Part no.	Boom		Capacity		OAH		Weight	
	ft	m	lbs	kg	in.	mm	lbs	kg
7100JA1W04	4	1.22	1000	453.6	44	1118	120	54.5
7100JA1W06	6	1.83	1000	453.6	44	1118	131	59.5
7100JA1W08	8	2.44	1000	453.6	44	1118	142	64.5
7080JA1W10	10	3.05	800	362.9	44	1118	153	69.5
7050JA1W12	12	3.66	500	226.8	44	1118	164	74.5
7036JA1W14	14	4.27	360	163.3	44	1118	175	79.5
7026JA1W16	16	4.88	260	117.9	44	1118	186	84.5
7020JA1W18	18	5.49	200	90.7	44	1118	197	89.5
7016JA1W20	20	6.1	160	72.6	44	1118	208	94.5

ZRA2 Boom Type Wall Mount (Heavy)								
Part no.	Boom		Capacity		OAH		Weight	
	ft	m	lbs	kg	in.	mm	lbs	kg
7200JA2W04	4	1.22	2000	907.2	44	1118	145	65.9
7200JA2W06	6	1.83	2000	907.2	44	1118	154	70
7200JA2W08	8	2.44	2000	907.2	44	1118	181	82.3
7190JA2W10	10	3.05	1900	861.8	44	1118	199	90.5
7160JA2W12	12	3.66	1600	725.7	44	1118	217	98.6
7135JA2W14	14	4.27	1350	612.3	44	1118	235	106.8
7100JA2W16	16	4.88	1000	453.6	56	1423	266	120.9
7080JA2W18	18	5.49	800	362.9	56	1423	310	140.9
7060JA2W20	20	6.1	600	272.2	56	1423	354	160.9

ZRS2 Boom Type Wall Mount (Medium)								
Part no.	Boom		Capacity		OAH		Weight	
	ft	m	lbs	kg	in.	mm	lbs	kg
7200JS2W04	4	1.22	2000	907.2	44	1118	145	65.9
7200JS2W06	6	1.83	2000	907.2	44	1118	163	74.1
7200JS2W08	8	2.44	2000	907.2	44	1118	181	82.3
7190JS2W10	10	3.05	1900	861.8	44	1118	199	90.5
7160JS2W12	12	3.66	1600	725.7	44	1118	217	98.6
7100JS2W14	14	4.27	1000	453.6	44	1118	235	106.8
7080JS2W16	16	4.88	800	362.9	56	1423	266	120.9
7060JS2W18	18	5.49	600	272.2	56	1423	310	140.9
7045JS2W20	20	6.1	450	204.1	56	1423	354	160.9

ZRS3 Boom Type Wall Mount (Heavy)								
Part no.	Boom		Capacity		OAH		Weight	
	ft	m	lbs	kg	in.	mm	lbs	kg
7200JS3W04	4	1.22	2000	907.2	44	1118	146	66.4
7200JS3W06	6	1.83	2000	907.2	44	1118	166	75.5
7200JS3W08	8	2.44	2000	907.2	44	1118	186	84.5
7195JS3W10	10	3.05	1950	884.5	44	1118	206	93.6
7160JS3W12	12	3.66	1600	725.7	44	1118	226	102.7
7135JS3W14	14	4.27	1350	612.3	44	1118	246	111.8
7100JS3W16	16	4.88	1000	453.6	56	1423	278	126.4
7080JS3W18	18	5.49	800	362.9	56	1423	322	146.6
7060JS3W20	20	6.1	600	272.2	56	1423	366	166.4

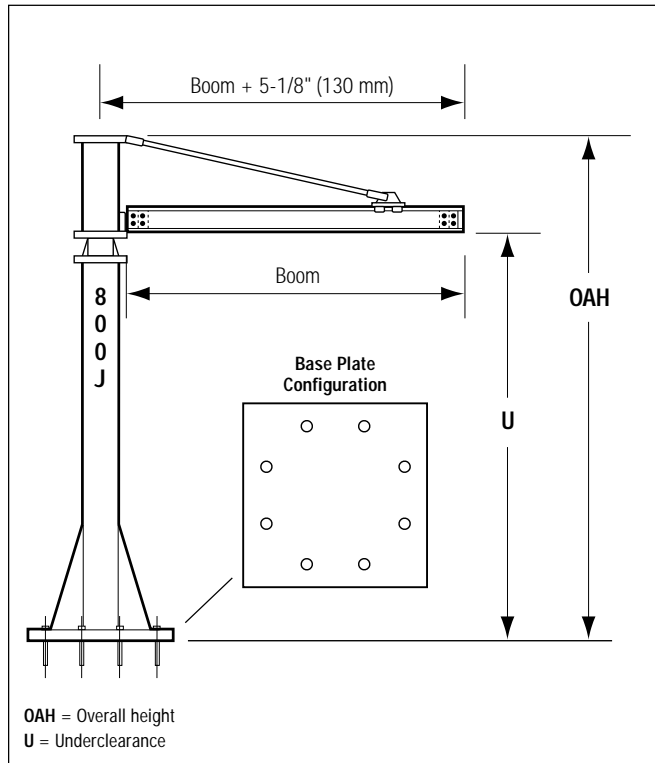

ZRA1 Boom Type 360° Rotation

Part no.	Boom		Capacity		OAH = U +		Weight	
	ft	m	lbs	kg	in.	mm	lbs	kg
8082JA1F04144	4	1.22	820	371.9	38	965	415	188.6
8055JA1F06144	6	1.83	550	249.5	38	965	423	192.3
8041JA1F08144	8	2.44	410	186	38	965	431	195.9
8033JA1F10144	10	3.05	330	149.7	38	965	439	199.5
8027JA1F12144	12	3.66	270	122.5	38	965	447	203.2
8023JA1F14144	14	4.27	230	104.3	38	965	455	206.8
8020JA1F16144	16	4.88	200	90.7	38	965	463	210.5
8018JA1F18144	18	5.49	180	81.6	38	965	471	214.1
8016JA1F20144	20	6.1	160	72.6	38	965	479	217.7

ZRA2 Boom Type 360° Rotation

Part no.	Boom		Capacity		OAH = U +		Weight	
	ft	m	lbs	kg	in.	mm	lbs	kg
8082JA2F04144	4	1.22	820	371.9	38	965	419	190.5
8055JA2F06144	6	1.83	550	249.5	38	965	435	197.7
8041JA2F08144	8	2.44	410	186	38	965	451	205
8033JA2F10144	10	3.05	330	149.7	38	965	467	212.3
8027JA2F12144	12	3.66	270	122.5	38	965	483	219.5
8023JA2F14144	14	4.27	230	104.3	38	965	499	226.8
8020JA2F16144	16	4.88	200	90.7	38	965	515	234.1
8018JA2F18144	18	5.49	180	81.6	38	965	531	241.4
8016JA2F20144	20	6.1	160	72.6	38	965	547	248.6

ZRS2 Boom Type 360° Rotation

Part no.	Boom		Capacity		OAH = U +		Weight	
	ft	m	lbs	kg	in.	mm	lbs	kg
8082JS2F04144	4	1.22	820	371.9	38	965	419	190.5
8055JS2F06144	6	1.83	550	249.5	38	965	435	197.7
8041JS2F08144	8	2.44	410	186	38	965	451	205
8033JS2F10144	10	3.05	330	149.7	38	965	467	212.3
8027JS2F12144	12	3.66	270	122.5	38	965	483	219.5
8023JS2F14144	14	4.27	230	104.3	38	965	499	226.8
8020JS2F16144	16	4.88	200	90.7	38	965	515	234.1
8018JS2F18144	18	5.49	180	81.6	38	965	531	241.4
8016JS2F20144	20	6.1	160	72.6	38	965	547	248.6

For applications not covered on this sheet or pallet based applications, consult the factory.

Dimensional Notes:

ZRA1, ZRA2 and ZRS2 (Medium)

U* Standard columns 6 x 6 x 1/4 in. designed for 144 in. (12 ft/3.7 m) under clearance or less.

P Base plate 3/4 x 18 x 18 in., 8-holes 7/8 in. diameter on a 16 in. (406.4 mm) bolt circle.

3/4 in. stud anchors or bolts are to be supplied by the customer.

Air supply kits

Size	Part no.
3/8"	90027
1/2"	90028

Note:

Includes filter regulator assembly with brackets, tagline assembly, and coiled hose

How to order

Jib Crane Model Driver

Style	Capacity	Jib	Rail type	Mount type	Boom length	Underclearance
7	080	J	S2	F	08	144
	lbs kg				ft m	in mm
7	080 = 080 36.4		A1 = ZRA1	F = Floor	04 = 4 1.22	144 = 144 3657.6
8	in 10s of lbs		A2 = ZRA2	W = Wall	06 = 6 1.83	
			S2 = ZRS2		08 = 8 2.44	
			S3 = ZRS3		10 = 10 3.05	
					12 = 12 3.66	
					14 = 14 4.27	
					16 = 16 4.88	
					18 = 18 5.49	
					20 = 20 6.10	

Best-In-Class Intelift Control System



The Intelift control module is a compact, integral element of the balancer itself. No cumbersome remote add-ons are necessary. It provides simple programming of functions with a keypad and indicator lights, and confirms settings with an easy-to-read display window. The closed loop feedback system delivers responsive motion control and a wide range of application options for vehicle assembly, general industry, beverage and warehouse as well as textile and electronics industries worldwide.

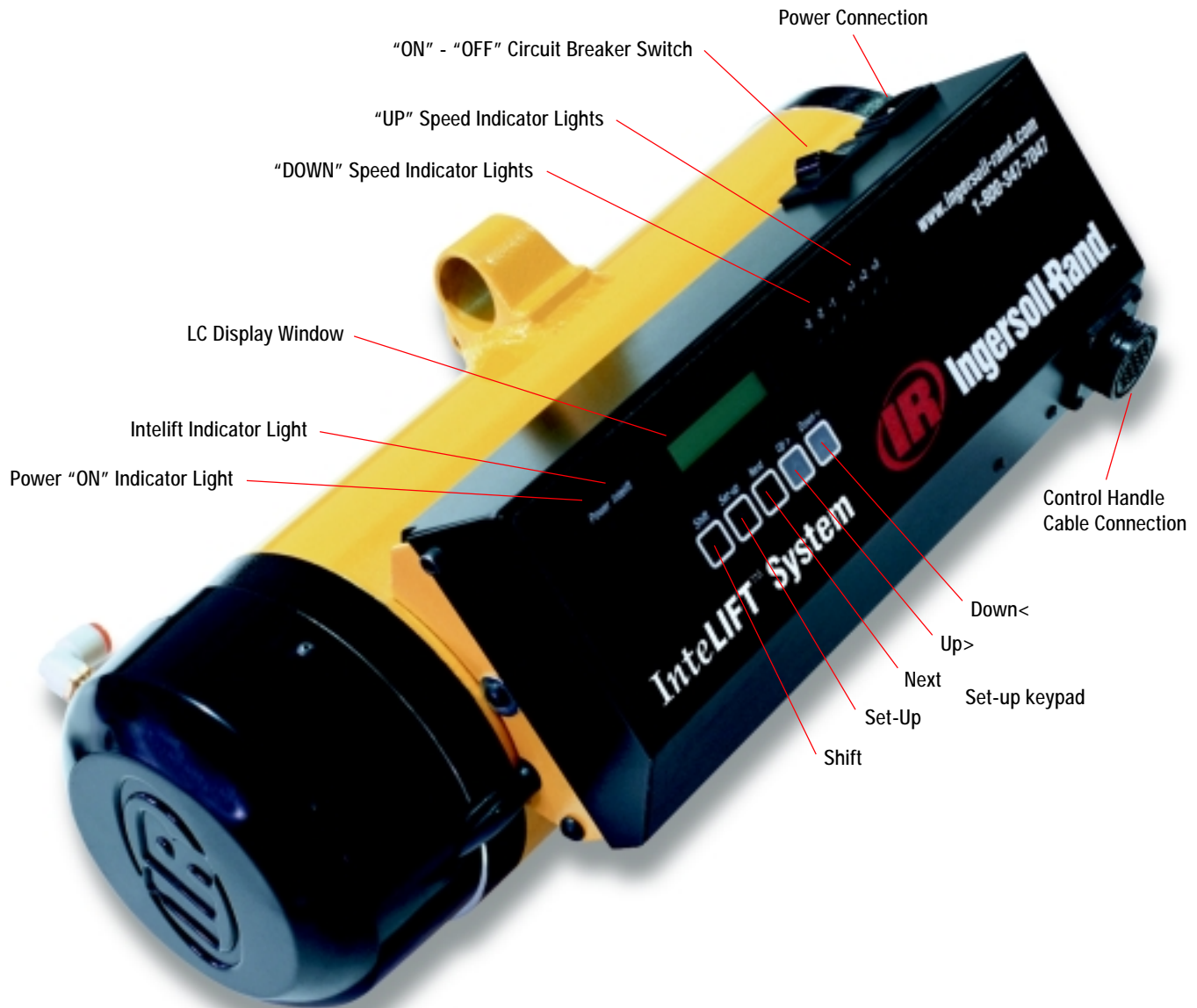

Intelift

Self-balance features enables intuitive speed control for different weights. **Float mode** allows the float capability through out the entire length of travel by maintaining constant pressure in the balancer using a pressure sensor. **Position control** through the **Dump mode** feature is achieved with closed loop feedback system. **Smart drop** feature allows lowering of the load until only the weight of the end effector is supported, reducing the sequence of operations. **Part present** feature enables clamping of parts in poor visibility. When used with vacuum cup devices, reduces air consumption and noise level. **Up control disable** feature ensures parts are securely clamped before permitting loads to be lifted. **The 3 speed select** feature further enhances the flexibility and productivity of the Intelift system.

New Ergonomically Superior Control Handle



The unique design of the control handle provides multi functional capabilities, reducing the sequence of operations and cycle time. The control handle is available in two styles:

- Pendant control handle
- Force Sensing control handle (no up/down buttons)

Emergency stop button



Intelift feature selection button

- P** – Light indicators on secondary controls
- Color coded buttons with standard symbols
- 3-speed select button
- Easy access controls
 - Clamp/Unclamp button
 - Up/Down rocker switch
- No up/down buttons necessary on the load cell based control handle

- S** Two tier design for primary and secondary controls

- P** Electronic end effector interface



- e** – Textured rubber grip
- Ergonomically shaped and optimized grip accommodate most hand sizes, as well as right and left-handed operators
- Intuitive, comfortable and ergonomic design

- \$** Common mounting interface for handling devices

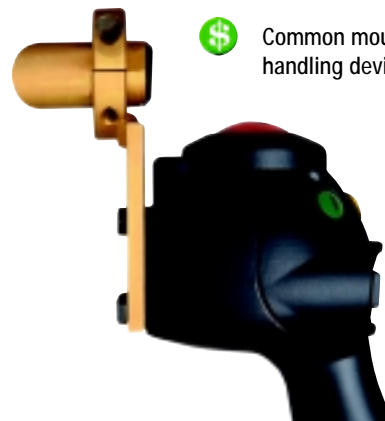

Intelift

Ingersoll-Rand Intelift air balancers combine the industry's finest, thoroughly proven mechanical balancing technology with the intelligence of precise, reliable electronic controls. This innovative combination is the first in a new series of intelligent lifting systems, and provides operators with a safe, ergonomically beneficial, and highly flexible solution that can enhance productivity and cost savings. The Intelift unit covers a capacity range of 150 lbs (68 kg) to 1,000 lbs (454 kg), with durability suited for 100 percent duty cycle and vertical speed capability of 300 ft per min.



➔ Designed for trolley or hook mount

- P** Self Balance Features
- Intuitive speed control for different weights
 - No adjustments needed for different weights
 - Increased productivity, cost savings with the same device
 - Improved safety and ergonomics

➔ Integral control box

💰 Ease of installation, no remote units

P Intuitive controls

⚡ 115 or 230 VAC voltage power supply

💰 Less than 1 AMP draw

- P** Load cell based control handle
- Provides intuitive motion control

P Low operating costs
Quiet operation
Fast Response

- P** Position Control with Dump Mode
- Accommodates pouring/dumping applications
 - Can lift part, add weight, remove weight & control position
 - One unit provides multiple functions

- ✔ Interlock
- Controlled part release
 - Increased release flexibility

➔ Flexibility

✔ Safety

👤 Ergonomics

P Productivity

💰 Cost Savings

A complete range of end effectors can be used with Intelift controls for greater efficiency, from the simplest to the most complex device. The Intelift unit incorporates a fully grounded, fault-protected electrical system, with fused circuits and memory that automatically reinstates function selections following a power interruption. In every respect, the Ingersoll-Rand Intelift air balancer is an essential solution for a more productive workplace, empowering individuals to work comfortably and effectively, significantly contributing to product and process quality.

- P** Float Mode Functions
 - Precise Positioning
 - Allows part manipulation
 - Can float the entire length of travel

+ Quick installation and set-up

! Patented Z-Brake
Other patents applied for

- P** 3 Speed Select
 - Offers flexibility to the operator
 - Offers application flexibility
 - Allows operator training at lower speeds

- P** Smart Drop Features
 - Pre-release interlock enhancement
 - Reduces sequence of operations

P Robust design for continuous duty with minimal maintenance

+ Simple operation for reduced training time and costs

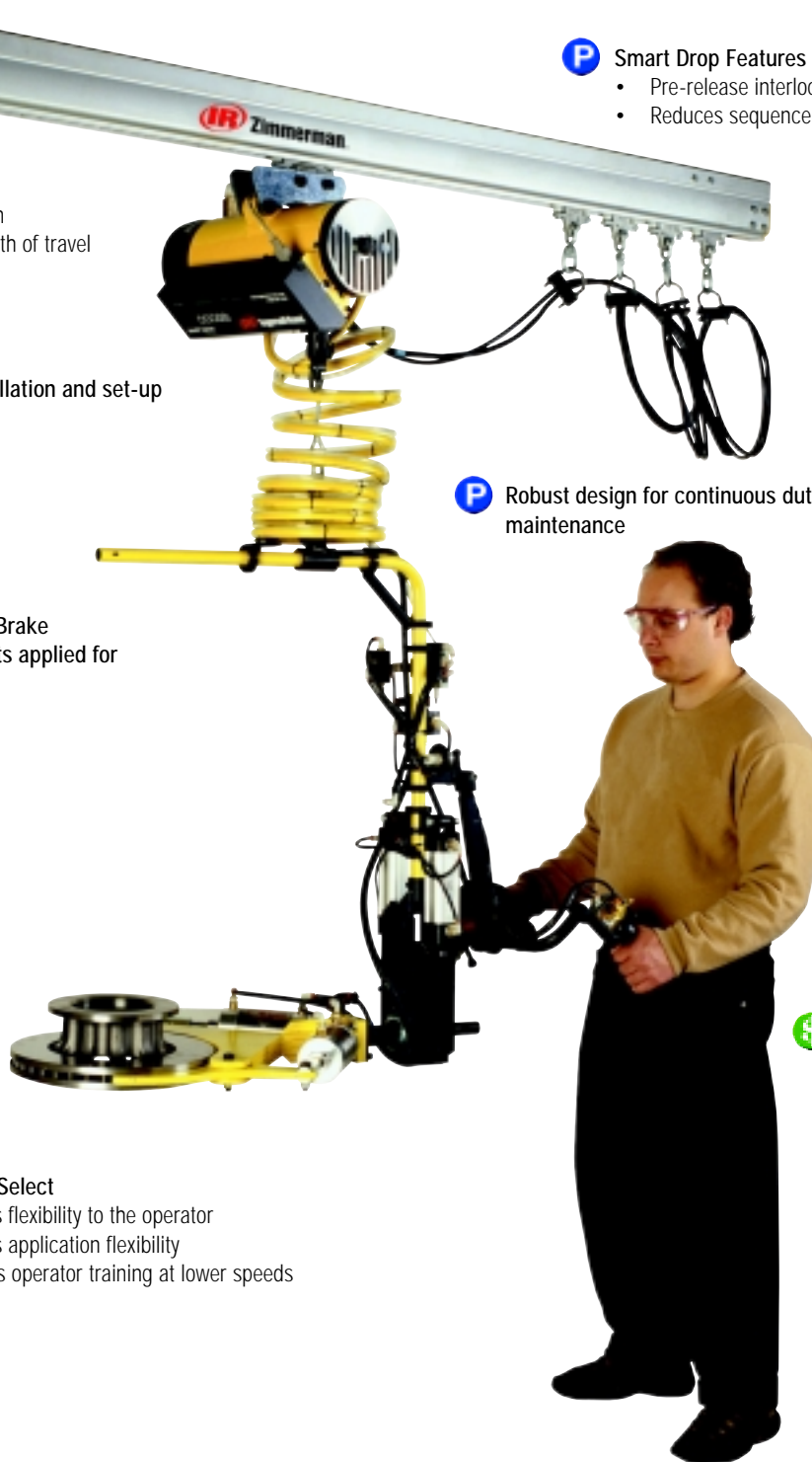

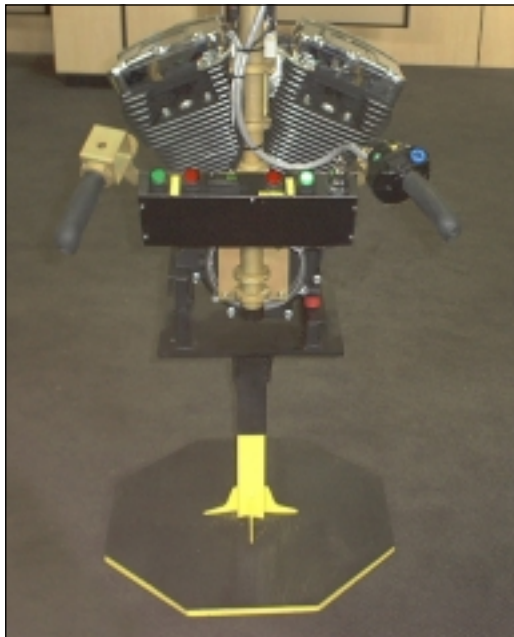

The engine handling device shown uses the unique features of the Intelift balancer. Features include: Auto Clamp, Interlock, Up control disable, weight sensing with automatic alarm, and keyed lock out.



Error proof assembly:
The device digitally displays the weight of the part picked up. Device will not allow the operator to move the part if not clamped properly. The key allows the operator the ability to lock the device. Allows 100% visual inspection of the assembly.



☞ The warehouse handling device shown is known for its versatility. The device mimics the human motion of picking a part and placing it. The same device can be used to pick up parts such as totes, trays, boxes, and milk crates. The second picture shows the same device lifting a different part. The self balance feature allows the same device to pick up parts of different weights and sizes.

**Call 1-800-347-7047
for distributors in your area**

P Productivity
The intelligent lifting systems shown above demonstrates speed and ease of use with minimal training required. The closed loop feedback system delivers responsive motion control and a wide range of application options.

Intelift Intelligent Lifting Unit Specifications



Intelift Control Options

- IB = Intelift Basic, no controls⁽²⁾
- IA = Intelift Pendant control handle with 12' twin bonded pre-coil cable
- IC = Intelift Force Sensing control handle with 12' twin bonded pre-coil cable
- IS = Intelift Pendant control handle with 12' straight electric cable



Intelift Air Balancers

Model	Capacity at 100 psi		Vertical hook travel		Diameter of Balancer		Net Weight	
	Single wire rope units	lbs	kg	in.	mm	in.	mm	lbs
IBW015080 ⁽¹⁾	150	68	80	2032	6.5	165	60	27
IBW020120	200	91	114	2896	10	254	72	33
IBW033080	330	150	70	1778	10	254	72	33
IBW050080	500	227	74	1880	10	254	120	54
IAW015080 ⁽¹⁾	150	68	80	2032	6.5	165	60	27
IAW020120	200	91	114	2896	10	254	72	33
IAW033080	330	150	70	1778	10	254	72	33
IAW050080	500	227	74	1880	10	254	120	54
ICW015080 ⁽¹⁾	150	68	80	2032	6.5	165	60	27
ICW020120	200	91	114	2896	10	254	72	33
ICW033080	330	150	70	1778	10	254	72	33
ICW050080	500	227	74	1880	10	254	120	54
ISW015080 ⁽¹⁾	150	68	80	2032	6.5	165	60	27
ISW020120	200	91	114	2896	10	254	72	33
ISW033080	330	150	70	1778	10	254	72	33
ISW050080	500	227	74	1880	10	254	120	54

Intelift Air Balancers

Model	Capacity at 100 psi		Vertical hook travel		Diameter of Balancer		Net Weight	
	Reeved units	lbs	kg	in.	mm	in.	mm	lbs
IBW040060	400	182	57	1448	10	254	65	30
IBW066040	660	300	35	883	10	254	77	35
IBW100040	1000	454	37	940	10	254	125	57
IAW040060	400	182	57	1448	10	254	65	30
IAW066040	660	300	35	889	10	254	77	35
IAW100040	1000	454	37	940	10	254	125	57
ICW040060	400	182	37	940	10	254	65	30
ICW066040	660	300	40	1016	10	254	77	35
ICW100040	1000	454	57	1448	10	254	125	57
ISW040060	400	182	57	1448	10	254	65	30
ISW066040	660	300	35	889	10	254	77	35
ISW100040	1000	454	37	940	10	254	125	57

Notes:

- (1) Not available with Z Stop option
- (2) Controls are required to operate the unit
- W=Wire rope

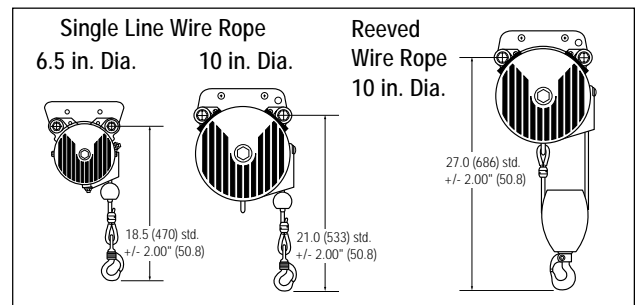
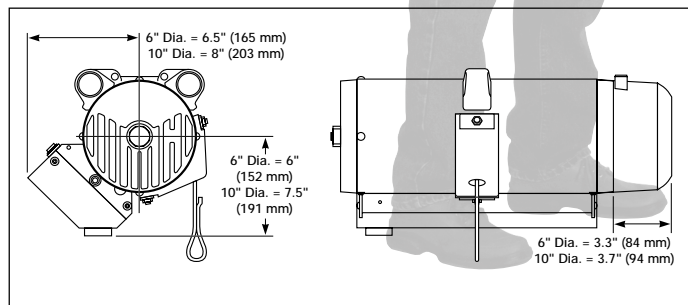

Intelift

Example: IAW020120A21SP

IA W 020 120 A2 1 S P

Intelift Control Options

- IB = Intelift Basic, no controls
- IA = Intelift Pendant control handle with 12' twin bonded pre-coil cable
- IC = Intelift Force Sensing control handle with 12' twin bonded pre-coil cable
- IS = Intelift Pendant control handle with 12' straight electric cable

Type

- W = Wire rope

Capacity

- 020 = 200 lbs (91kg) [for available capacities, refer to model number tables]

Travel

- 120 = 120 inches (3048mm) [for available travel, refer to model number tables]

Suspension Options

- 00 = No Suspension
- S2 = ZRS2 steel rail
- S3 = ZRS3 steel rail
- HM = Hook Mount
- TR = T-Rail / I-Beam
- AT = ZRAT Aluminum rail
- A1 = ZRA1 Aluminum rail
- A2 = ZRA2 Aluminum rail
- E4 = ETA-4 Aluminum Rail
- E8 = ETA-8 Aluminum Rail
- G1 = Gorbel 1000# Alum. Series Track
- G2 = Gorbel 1000# Steel. Series Track
- K1 = KBK1 Steel Rail
- K2 = KBK2 and KBK2L Steel Rail
- K3 = 4" Aluminum, Knight
- K4 = 8" Aluminum, Knight
- K5 = 8" Aluminum Anti Kick Back, Knight
- K6 = 4" Steel, Knight
- E7 = 6" Steel, Knight
- K8 = 7" Steel, Knight

Voltage Options

- 1 = 115V 50/60Hz 1PH
- 2 = 230V 50/60Hz 1PH

Z-Stop Option

- 0 = None
- S = Z-Stop

Power Cord Option

- 0 = None
- P = 6' Power Cord

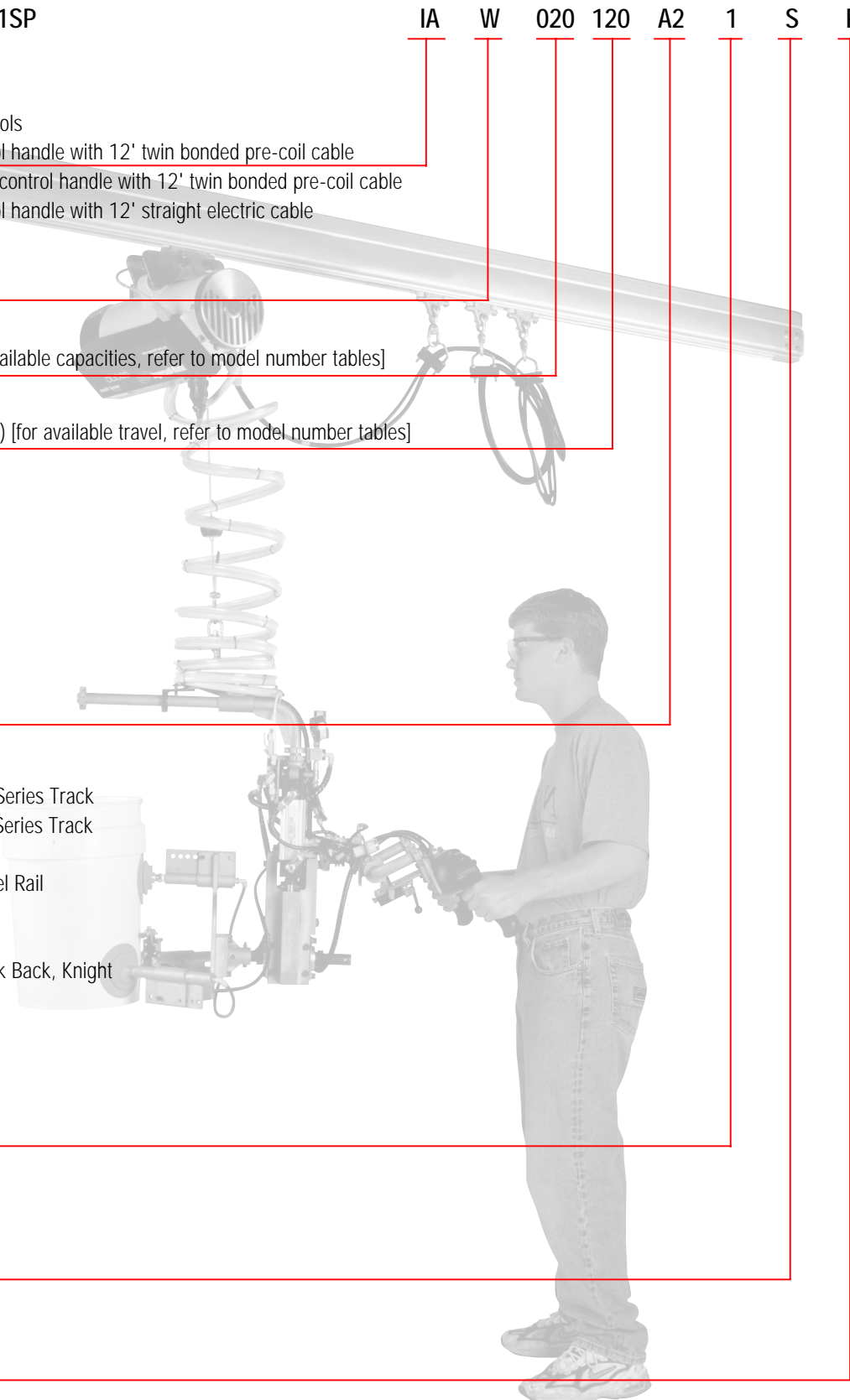

Intelift

Pneumatic Balancers

50 to 2000 lbs (22 to 909 kg) Capacity



The Strength Behind Material Handling Technology

Meeting the needs of today's material handling applications requires an ergonomic lift assist that interacts with the operator. The Balancer offers lifting solutions to meet these needs through float and built in safety features.

Balancer Advantage

Precise, strain-free positioning – Float leaves both hands free to raise, lower, or shift the load with virtually no resistance. No more “hoist control” hit-and-miss spotting.

Simple adjustment – Clear access to air-flow calibration controls allows quick, easy adjustment of the float.

Low air consumption – Approximately 1/8 cfm required per cycle (50 times less than an air hoist), means very low energy costs.

Clean, oil-free operation – Pre-lubricated design – Eliminates air line lubrication and oil mist exhaust. It's ideal for food processing and clean manufacturing environments.

Rugged reliability – for continuous duty with minimal maintenance, the Balance Air delivers cost effective performance.

Safety is Standard

Built-in overload protection – The load being lifted can never exceed the unit's maximum rated capacity for a given air pressure. Maximum capacity is rated at 100 psig and actual capacity is linearly proportional to actual pressure. For example, at 70 psig the unit can only lift up to 70% of its maximum capacity.

Minimal cable recoil due to loss of load – If the load is accidentally lost, a spring-loaded centrifugal brake (Z brake) automatically stops rapid upward cable travel.

Versatile configuration

Wide range of capacities – Balancers are rated from 50 to 2,000 pounds (22 to 909 kg) maximum, with lower capacity units adjustable for loads as low as 2 pounds (.9 kg). Tandem units handle larger loads.

Added protection – The optional Z Stop offers protection against the drifting of loads in the event the main air supply is lost.

Cable travel – The range of up/down movement varies from 40 to 120 inches, (1016 to 3048 mm) depending on the model.

Controls – ZA (pendant) controls let you handle varying loads; a BA (single) balance control is ideal for a constant load, and an EA for 2 loads.

Mounting – Suspension kits for Zimmerman and other enclosed track manufacturers as well as I-Beam, patented track, and hook mount.

CE Certification – Meets the requirements for the European Community.



Balancer with ZA pendant control



Z Stop: The optional Z Stop is a patent pending device that will eliminate the down-drift of suspended loads or tools during shut down or at night when the air supply is shut off. The Z Stop will stop drift within 6 inches (152.4 mm) and put the Balance Air into a mechanically locked position preventing damage to tools or objects below the suspended load. Available for use on all 10 inch (254 mm) diameter units.



Available in 6.5 inch (165.1 mm) and 10 inch (254 mm) can sizes

Pneumatic Balancers

50 to 2000 lbs (22 to 909 kg) Capacity



**Z Brake Safety Retraction System:
(Patent No. 5,522,581)**

Prevents violent retraction in the event of a sudden release or loss of load. The brake will also eliminate excessive upward acceleration of a no load hook when the "up" button is employed to full depression. This system is available on all units (except 50 lb/22 kg units) equipped with either cable or chain.

**Optional
Z Stop
location**

Suspension lugs: Fits all Zimmerman suspensions and most trolleys from other manufacturers.

Rugged steel housing: All steel housing for added durability

Injection molded reel: Engineered plastic for excellent durability and wear resistance.

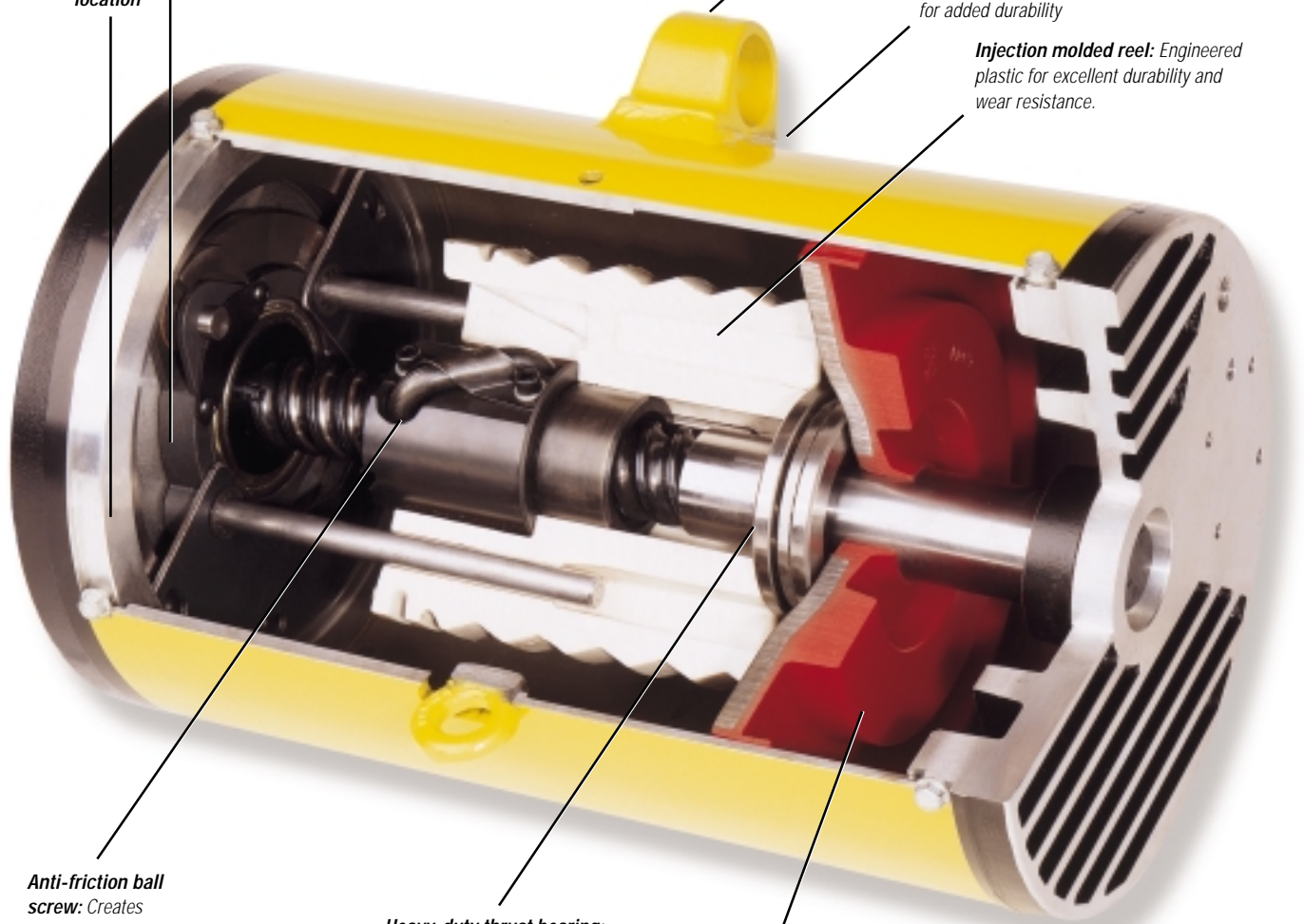

Anti-friction ball screw: Creates smooth rotation path for the cable reel.

Heavy-duty thrust bearing: Absorbs piston force and transfers smooth reel rotation over the ball screw.

Low-friction cable guide (not shown): Ensures smooth cable feed on and off the reel.

Air chamber and piston: Forms the heart of the unit. Air entering the chamber pushes the piston to rotate the spool, wind the cable, and lift the load. Exhausting air lowers the load. Regulating this flow balances the load, creating a zero gravity float.

Balancers

Pneumatic Balancers

50 to 2000 lbs (22 to 909 kg) Capacity



Control and Suspension Options

(BA) Single Balance Control: A Balancer equipped with the (BA) Single Balance control is an excellent alternative to traditional spring balancers. The balance range of a single capacity Balancer is equivalent to that of 10 different capacity spring balancers with the main difference being that the Balancer maintains constant tension throughout its full range of travel.

Suitable for:

- Tool Balancing
- Weld Gun Suspension
- Fixture Suspension

(ZA) Pendent Control: The (ZA) Pendent Control is designed for high speed precision handling of variable weight loads. Up/Down movement is accomplished through the use of an ergonomically designed pendent with low-effort, color-coded thumb levers. After positioning the load with the pendent control, the unit defaults into a zero gravity float condition allowing the operator up to 18 inches (457.2 mm) of float for final positioning.

(EA) Hi, Lo, Un Load Control: Balancers equipped with the (EA) control are designed to excel in high speed, constant weight, repetitive parts handling operations. The control positions are thumb actuated and are used to switch the unit to accommodate different load modes as required.

These are as follows:

HILOAD: Used to pick up or balance the maximum weight load.

LOLOAD: Used to balance, lower, and precisely position the load.

UNLOAD: Used to release and balance the empty hook.



*Balancer with
BA Z-Servo control*



*Balancer with
ZA pendent control*



*Balancer with
EA Hi load, Lo load,
No load control*

Pneumatic Balancers

50 to 2000 lbs (22 to 909 kg) Capacity



Balancer with I-Beam/Patented Track trolley mount configuration



Balancer with hook mount configuration



Balancer with enclosed rail trolley mount configuration

The 50 lb Tool Series

This air unit offers an incredible 2 to 50 pound (.9 to 22 kg) load capacity. A range our competitors achieve only with numerous models designed for individual load weight. Designed and manufactured in the United States, the 50 lb Balancer offers numerous other benefits over spring operated units, including our exclusive flotation feature.

Standard Features

Performance – Float action provides ease of vertical travel, eliminating tension on load making positioning capability far superior.

Versatility – No need to change model when making tool change: one model (BAW005060) covers entire 50 lb (22 kg) range.

Headroom – Requires only 20 inches (508 mm) from bottom of rail to bottom of hook.

Adjustment – Simple adjustment in seconds by means of external regulator.

Sequencing – Can be sequenced via air signal to perform timed or “stepped” operation.

Maintenance – Virtually maintenance-free. Normal maintenance can be done in place on the rail.

Installation – Requires air hookup (can be tied into tooling air supply).

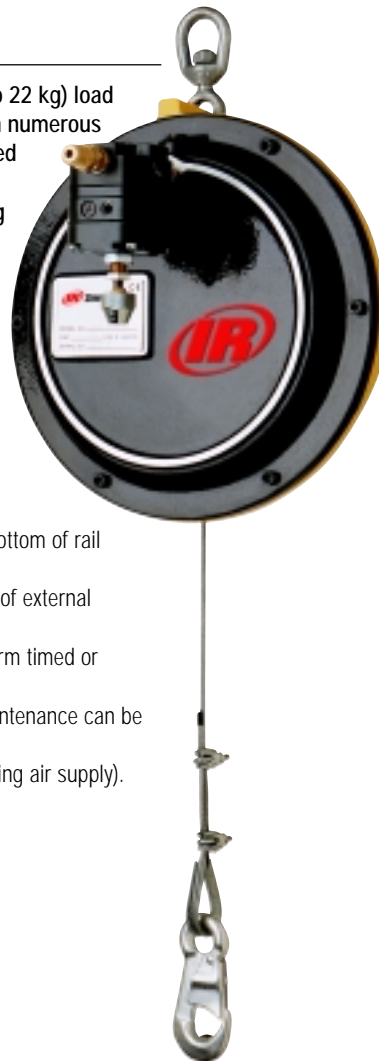

EZ Grip Ergonomic Handle

Quality manufactured handle by IR Zimmerman International Corporation, the world leader in ergonomically sound material handling equipment. Rugged, durable construction handle with three mounting options. The handle can be used as a pendent control, rigid mount, or with an optional ball and socket mount. This handle can be used on most air actuated devices, including air hoists, and can be operated with or without gloves.



Balancers

Pneumatic Balancers

50 to 2000 lbs (22 to 909 kg) Capacity



Dimensions

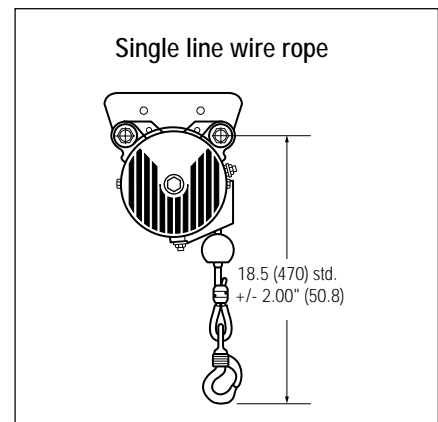
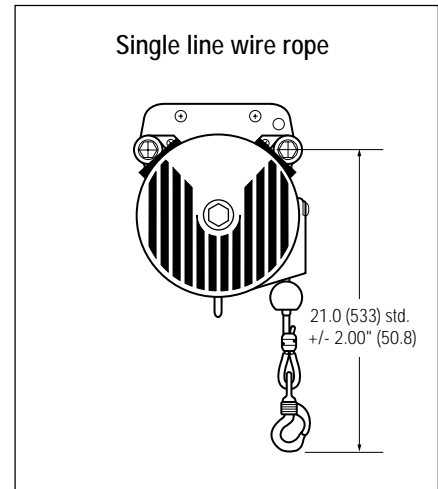
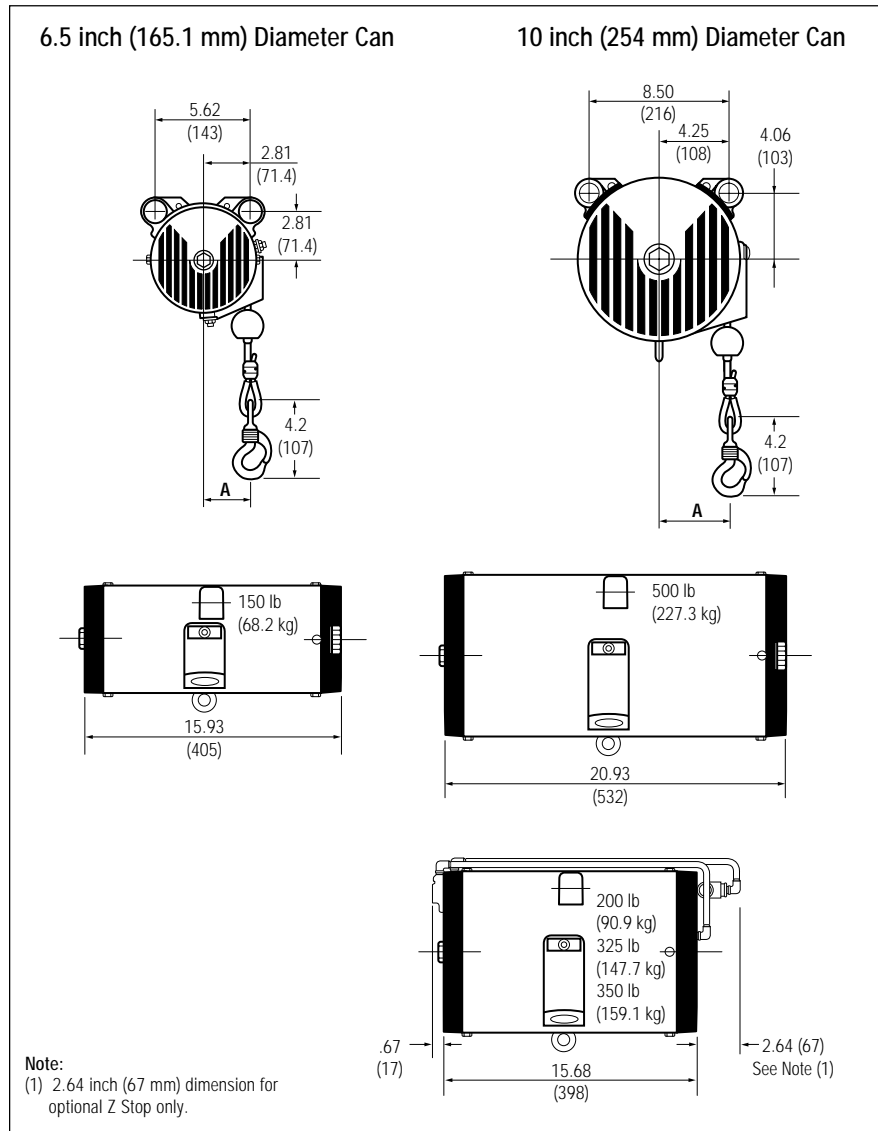

Note:
 For all drawings, dimensions in () are in mm

Dimensions

Load capacity		Type	"A" Dimensions	
lbs	kg		in.	mm
150	68	W	2.85	72.4
200	90	W	4.10	104.1
350	158	W	2.85	72.4
350	158	C	2.79	70.9
500	227	W	3.62	91.9
500	227	C	3.51	89.2

Balancers

Pneumatic Balancers

50 to 2000 lbs (22 to 909 kg) Capacity



Dimensions

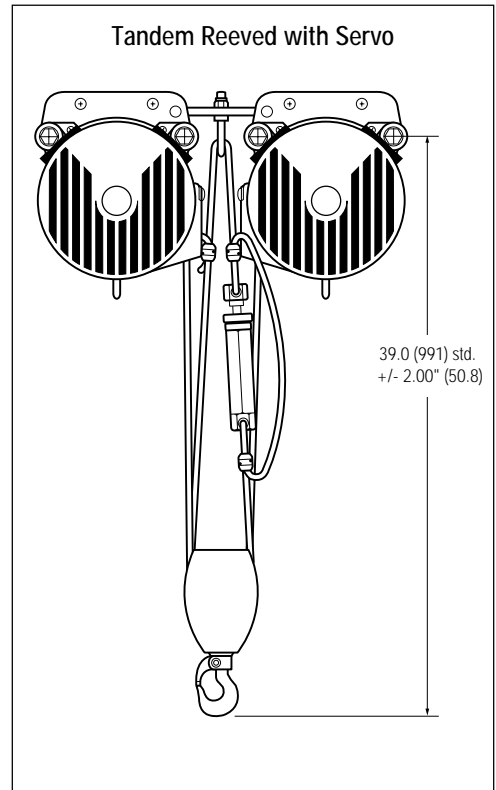
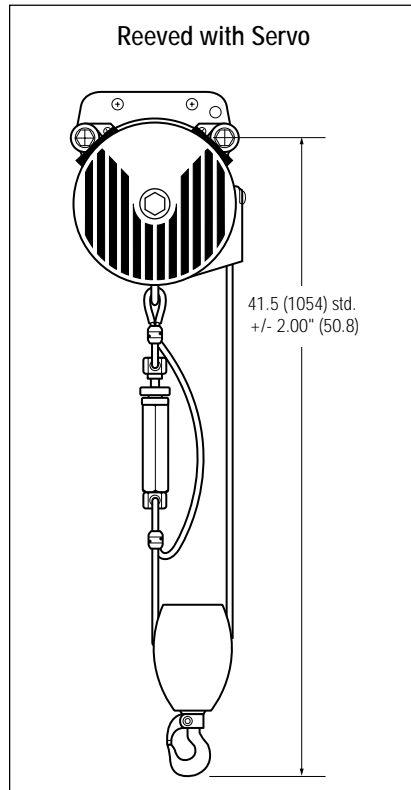
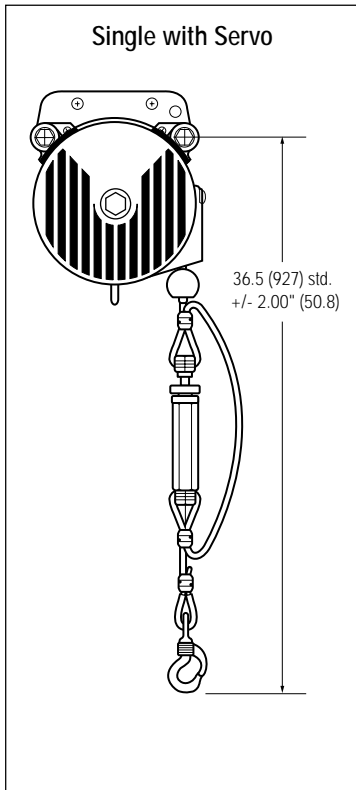
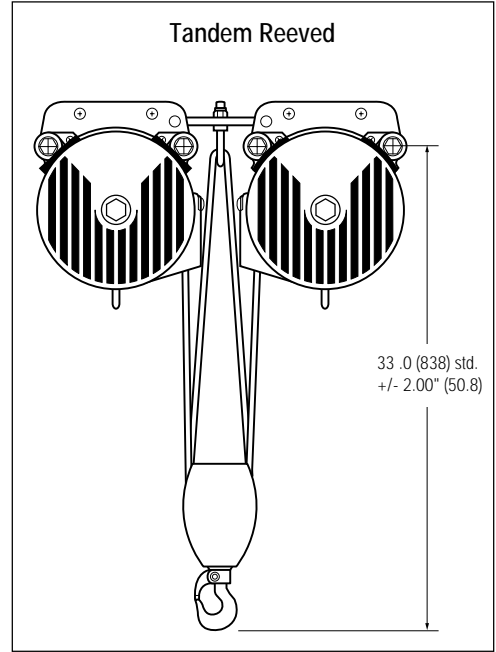
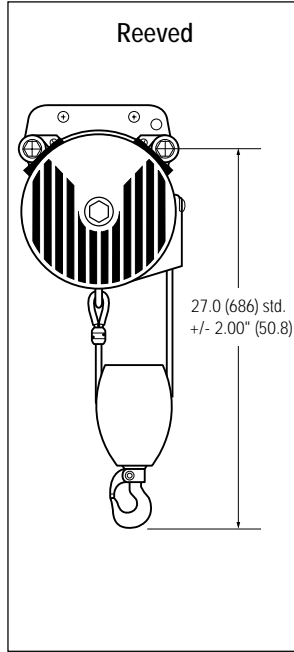
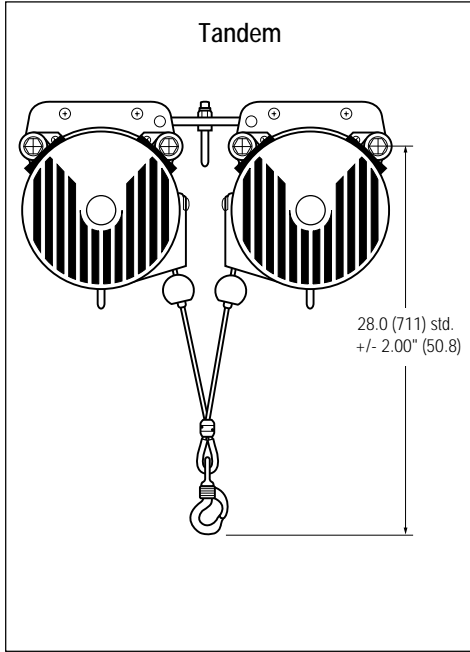

Note:
For all drawings, dimensions in () are in mm

Pneumatic Balancers

50 to 2000 lbs (22 to 909 kg) Capacity



Specifications									
Model no.	Capacity		Vertical travel		Diameter of positioner		Net weight		
	lbs	kg	in.	mm	in.	mm	lbs	kg	
Single Wire Rope Units									
BW005060 ¹	50	22	60	1524	–	–	20	9	
BW015080 ¹	150	68	80	2032	6.5	165	50	23	
BW020120	200	90	120	3048	10	254	62	28	
BW032080 ²	325	147	80	2032	10	254	62	28	
BW035080 ¹	350	158	80	2032	10	254	62	28	
BW050080	500	227	80	2032	10	254	110	50	
Reeved Wire Rope Units									
BW040060	400	181	60	1524	10	254	67	30	
BW065040 ²	650	294	40	1016	10	254	67	30	
BW070040 ¹	700	317	40	1016	10	254	67	30	
BW100040	1000	453	40	1016	10	254	115	52	
Tandem Wire Rope Units									
BW040120	400	181	120	3048	10	254	124	56	
BW065080 ²	650	294	80	2032	10	254	124	56	
BW070080 ¹	700	317	80	2032	10	254	124	56	
BW100080	1000	453	80	2032	10	254	220	100	
Tandem Reeved Wire Rope Units									
BW080060	800	360	60	1524	10	254	129	59	
BW130040 ²	1300	589	40	1016	10	254	129	59	
BW140040 ¹	1400	620	40	1016	10	254	129	59	
BW200040	2000	900	40	1016	10	254	225	102	

Notes:

- (1) Not available with Z Stop option
- (2) Only available with Z Stop option

Options		
Option code	Description	Part no.
S	Z-Stop	
Control Options code		
B	Basic–no controls	
ZA	Pendant control	15300–12
BA	Single balance control–6.5" unit	15320
BA	Single balance control–10" unit	15330
EA	Hi, low, no load control	15310–12

Note:

ZA and EA control packages standard hose length 12'-0" (3.7 m).

Pneumatic Balancers

50 to 2000 lbs (22 to 909 kg) Capacity



Suspension Options ⁽¹⁾				
Option code	Description	6.5"	10"	Competitor Product
00	No suspension	–	–	NA
S2	ZRS2 steel rail	16300	16400	NA
S3	ZRS3 steel rail	16300	16400	NA
HM	Hook mount	16360	16460	NA
TR	T-Rail / I-Beam	16320	16420	NA
AT	ZRAT aluminum rail	16355	16455	NA
A1	ZRA1 aluminum rail	16305	16405	NA
A2	ZRA2 aluminum rail	16310	16410	NA
E4	ETA-4 aluminum rail	16344	16444	Unified
E8	ETA-8 aluminum rail	16335	16435	Unified
K1	KBK1 steel rail	16325	16425	Demag
K2	KBK2 steel rail	16315	16415	Demag
G1	Gorbel 1000# Alum. Series Track	16307	16407	Gorbel
G2	Gorbel 1000# Steel Series Track	16307	16407	Gorbel
K3	4" Aluminum	16344	16444	Knight
K4	8" Aluminum	16345	16445	Knight
K5	8" Aluminum Anti Kick Back	16345	16445	Knight
K6	4" Steel	16325	16245	Knight
K7	6" Steel	16315	16415	Knight
K8	7" Steel	16315	16415	Knight

Note:
(1) Tandem units require two suspension kits.

How to order

Pneumatic Balancers Model Driver

Control <i>B</i>	Type <i>W</i>	Capacity <i>020</i>	Travel <i>120</i>	Options <i>S</i>	Suspension <i>S2</i>		
<i>B</i> = Basic, no controls	<i>W</i> = Wire Rope	Wire 005 ¹ = 50 015 ¹ = 150 020 = 200 032 ² = 325 035 ¹ = 350 040 = 400 050 = 500 065 ² = 650 070 ¹ = 700 080 = 800 100 = 1000 130 ² = 1300 140 ¹ = 1400 200 = 2000	lbs 22 68 90 147 158 181 227 294 317 362 453 589 365 907	kg 22 68 90 147 158 181 227 294 317 362 453 589 365 907	<i>120</i> = 120 inches Travel distance is determined by series and capacity, and is not a variable option. See model no. in specifications chart. Example: BW020120	<i>S</i> = Z-Stop	00 = No suspension S2 = ZRS2 steel rail S3 = ZRS3 steel rail HM = Hook mount TR = T-Rail / I-Beam AT = ZRAT aluminum rail A1 = ZRA1 aluminum rail A2 = ZRA2 aluminum rail E4 = ETA-4 aluminum rail E8 = ETA-8 aluminum rail K1 = KBK1 steel rail K2 = KBK2 steel rail G1 = Gorbel 1000# Alum. Series Track G2 = Gorbel 1000# Steel Series Track K3 = 4" Aluminum K4 = 8" Aluminum K5 = 8" Aluminum Anti Kick Back K6 = 4" Steel K7 = 6" Steel K8 = 7" Steel

Notes:
(1) Not available with Z-Stop option
(2) Only available with Z-Stop option

As an alternative for reaching in, under, and around obstacles, Zimmerman Arm Systems allow an operator to precisely and effortlessly position loads regardless of physical strength.

Fitted with one of our standard or custom End Effectors, our Manipulator Arm Systems can perform a wide variety of material handling applications. Our full line of Arms offer the most flexibility available on the market today.



450 Arm shown with optional clamp end effector

600 Series Arms

Consist of a rigid vertical beam with a moving horizontal beam that is able to reach into an opening. These arms also utilize the Balance Air® for lifting and balancing power.

- Allows for reach in and off center applications.
- Variety of End Effector combinations.
- Can be adapted to most rail systems.



600 Arm shown with optional probe

400 Series Arms

Utilizing a parallel link design to maintain either end effector or tool orientation, these arms allow an operator to reach into an opening and manipulate a part or tool.

700 Series Arms

Consisting of a connecting linkage type boom that folds within itself to offer a large coverage area, these arms utilize the Balance Air® lifting and balancing unit as the lifting power.



Self contained system with RAH, 720 arm, and 24 volt compressor integrated onto battery powered pallet truck. Integration to trucks, not performed by IR Zimmerman.

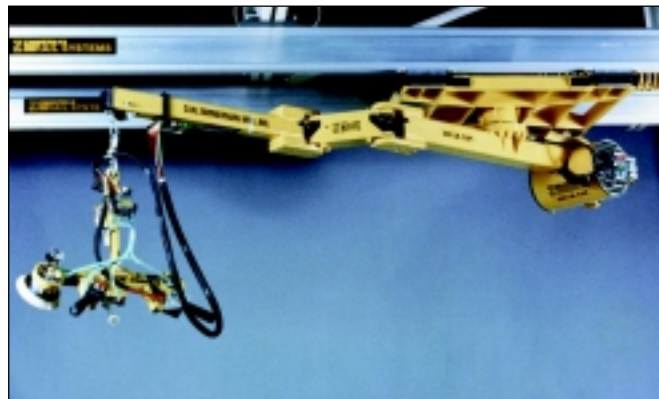

700 C Arm (carriage mount) shown with optional end effector

Arm Systems

Series 700C



Series 700C Arm

Part No.	Arm Length		Capacity		Weight	
	ft	m	lbs	kg	lbs	kg
70015@A**?++06#	6	1.83	150	65	218	99
70015@A**?++07#	7	2.13	150	65	237	108
70015@A**?++08#	8	2.44	150	65	248	113
70015@A**?++09#	9	2.74	150	65	263	120
70015@A**?++10#	10	3.05	150	65	275	125
70020@A**?++06#	6	1.83	200	90	248	113
70020@A**?++07#	7	2.13	200	90	267	121
70020@A**?++08#	8	2.44	200	90	278	126
70020@A**?++09#	9	2.74	200	90	278	126
70020@A**?++10#	10	3.05	200	90	304	138
70035@A**?++06#	6	1.83	350	155	257	117
70035@A**?++07#	7	2.13	350	155	279	127
70035@A**?++08#	8	2.44	350	155	290	132
70035@A**?++09#	9	2.74	350	155	290	132
70035@A**?++10#	10	3.05	350	155	316	144
70050@A**?++06#	6	1.83	500	225	271	123
70050@A**?++07#	7	2.13	500	225	290	132
70050@A**?++08#	8	2.44	500	225	328	149
70050@A**?++09#	9	2.74	500	225	350	159
70050@A**?++10#	10	3.05	500	225	367	167

Series 700C Arm - Dimensions (inches)

Capacity (lbs)	Top mt							Bottom mt			
	A	B	C	D	G	J	K	H	L		
150	72	26	34	6.78	4.25	23.75	12	13.25	8	7.75	13.53
150	84	38	34	6.78	4.25	23.75	12	13.25	8	7.75	13.53
150	96	38	46	6.78	4.25	23.75	12	13.25	8	7.75	13.53
150	108	38	46	6.78	4.25	23.75	24	13.25	8	7.75	13.53
150	120	38	46	6.78	4.25	23.75	36	13.25	8	7.75	13.53
200	72	26	34	6.78	4.25	26	12	13.25	11.13	7.75	13.66
200	84	38	34	6.78	4.25	26	12	13.25	11.13	7.75	13.66
200	96	38	46	6.78	4.25	26	12	13.25	11.13	7.75	13.66
200	108	38	46	6.78	4.25	26	24	13.25	11.13	7.75	13.66
200	120	38	46	6.78	4.25	26	36	13.25	11.13	7.75	13.66
350	72	26	34	6.78	4.25	27	12	13.25	9.96	7.75	14.47
350	84	38	34	6.78	4.25	27	12	13.25	9.96	7.75	14.47
350	96	38	46	6.78	4.25	27	12	13.25	9.96	7.75	14.47
350	108	38	46	6.78	4.25	27	24	13.25	9.96	7.75	14.47
350	120	38	46	6.78	4.25	27	36	13.25	9.96	7.75	14.47
500	72	26	34	6.78	4.25	27	12	13.25	10.63	7.75	14.16
500	84	38	34	6.78	4.25	27	12	13.25	10.63	7.75	14.16
500	96	38	46	8.5	5.5	27	12	13.25	11.38	7.75	16.63
500	108	38	46	8.5	5.5	27	24	13.25	11.38	7.75	16.63
500	120	38	46	8.5	5.5	27	36	13.25	11.38	7.75	16.63

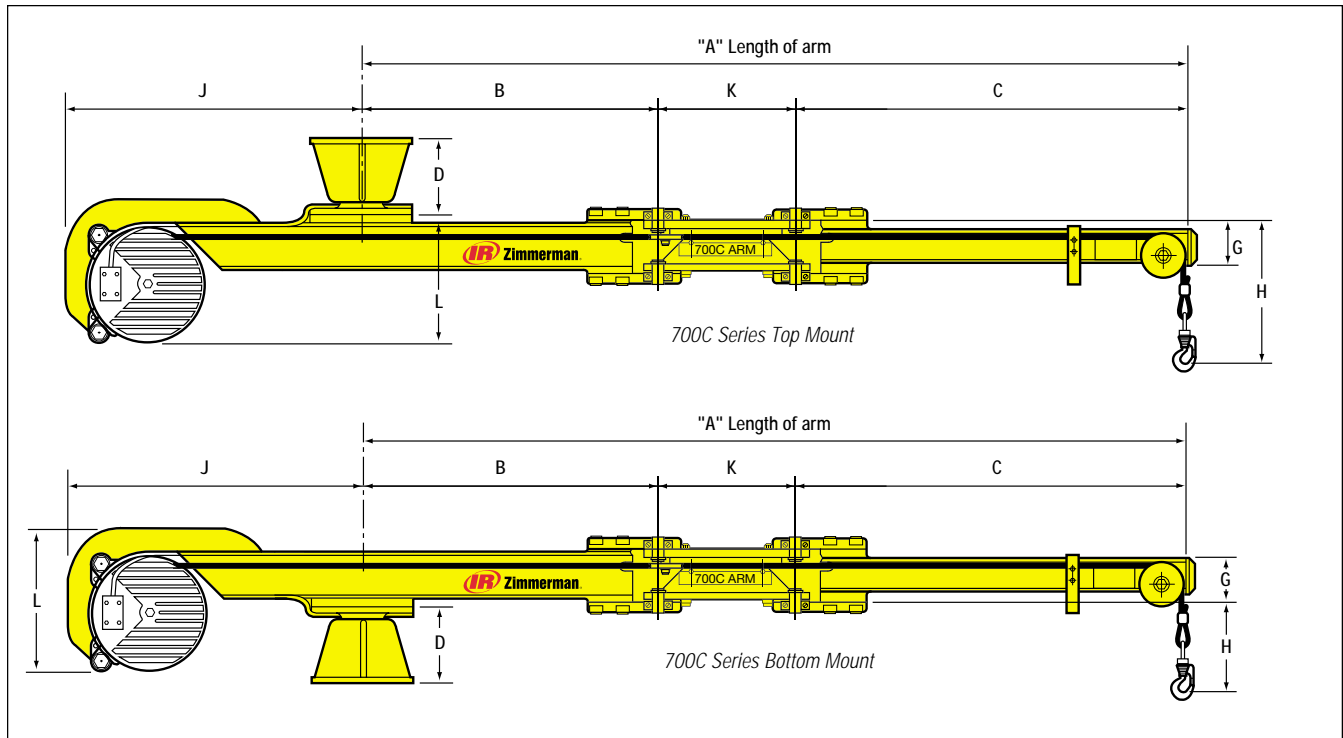

Arm Systems

Arm Systems

Series 701C



Series 701C Arm						
Part No.	Arm Length		Capacity		Weight	
	ft	m	lbs	kg	lbs	kg
70115@A**?++06#	6	1.83	150	65	218	99
70115@A**?++07#	7	2.13	150	65	237	108
70115@A**?++08#	8	2.44	150	65	248	113
70115@A**?++09#	9	2.74	150	65	263	120
70115@A**?++10#	10	3.05	150	65	275	125

Series 701C Arm - Dimensions (inches)									
Capacity (lbs)						Top mt		Bottom mt	
	A	B	C	D	E	H	L	H	L
150	72	18	12	6.78	42	12.12	16.97	7.12	11.03
150	84	30	12	6.78	42	12.12	16.97	7.12	11.03
150	96	42	12	6.78	42	12.12	16.97	7.12	11.03
150	108	26	26	6.78	56	12.12	16.97	7.12	11.03
150	120	48	18	6.78	54	12.12	16.97	7.12	11.03

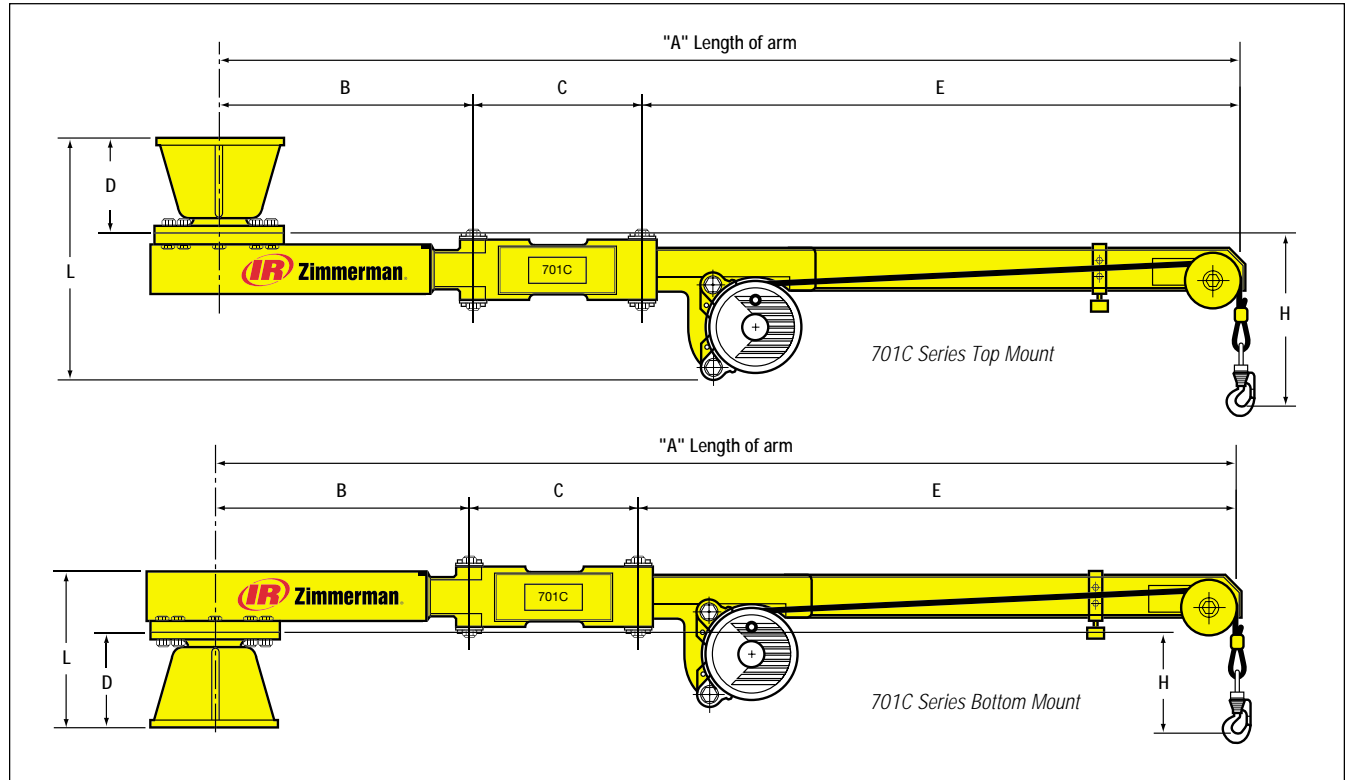

Arm Systems

Series 713



Series 713 Arm

Part No.	Arm Length		Capacity		Weight	
	ft	m	lbs	kg	lbs	kg
71315@A**?+06#	6	1.83	150	65	151	69
71315@A**?+07#	7	2.13	150	65	166	75
71315@A**?+08#	8	2.44	150	65	175	80
71315@A**?+09#	9	2.74	150	65	184	84
71315@A**?+10#	10	3.05	150	65	228	104
71320@A**?+06#	6	1.83	200	90	197	90
71320@A**?+07#	7	2.13	200	90	213	97
71320@A**?+08#	8	2.44	200	90	224	102
71320@A**?+09#	9	2.74	200	90	235	107
71320@A**?+10#	10	3.05	200	90	281	128
71335@A**?+06#	6	1.83	350	155	233	106
71335@A**?+07#	7	2.13	350	155	246	112
71335@A**?+08#	8	2.44	350	155	261	119
71335@A**?+09#	9	2.74	350	155	258	117
71335@A**?+10#	10	3.05	350	155	271	123
71350@A**?+06#	6	1.83	500	225	261	119
71350@A**?+07#	7	2.13	500	225	275	125
71350@A**?+08#	8	2.44	500	225	276	125
71350@A**?+09#	9	2.74	500	225	335	152
71350@A**?+10#	10	3.05	500	225	351	160

Series 713 Arm - Dimensions (inches)

Capacity (lbs)	Top mt								Bottom mt			
	A	B	C	D	F	G	H	E	K	E	K	L
150	72	41	31	6.78	9.19	3	10	5.46	3	4.75	8.5	11.53
150	84	47	37	6.78	9.19	3	10	5.46	3	4.75	8.5	11.53
150	96	53	43	6.78	9.19	3	10	5.46	3	4.75	8.5	11.53
150	108	59	49	6.78	9.19	3	10	5.46	3	4.75	8.5	11.53
150	120	65	55	6.78	9.19	3	10	5.46	3	4.75	8.5	11.53
200	72	41	31	6.78	12.81	4	9	5.46	3	4.75	8.5	11.53
200	84	47	37	6.78	12.81	4	9	5.46	3	4.75	8.5	11.53
200	96	53	43	6.78	12.81	4	9	5.46	3	4.75	8.5	11.53
200	108	59	49	6.78	12.81	4	9	5.46	3	4.75	8.5	11.53
200	120	65	55	6.78	12.81	4	9	5.46	3	4.75	8.5	11.53
350	72	41	31	6.78	12.81	4	9	5.54	3	4.75	8.5	11.53
350	84	47	37	6.78	12.81	4	9	5.54	3	4.75	8.5	11.53
350	96	53	43	6.78	12.81	4	9	5.54	3	4.75	8.5	11.53
350	108	59	49	6.78	12.81	4	9	6.78	3	6	8.5	12.78
350	120	65	55	6.78	12.81	4	9	6.78	3	6	8.5	12.78
500	72	41	31	6.78	12.81	4	9	5.54	3	4.75	8.5	11.53
500	84	47	37	6.78	12.81	4	9	5.54	3	4.75	8.5	11.53
500	96	53	43	8.5	12.81	4	9	6.79	3	6	8.5	14.5
500	108	59	49	8.5	12.81	4	9	6.79	3	6	8.5	14.5
500	120	65	55	8.5	12.81	4	9	6.79	3	6	8.5	14.5

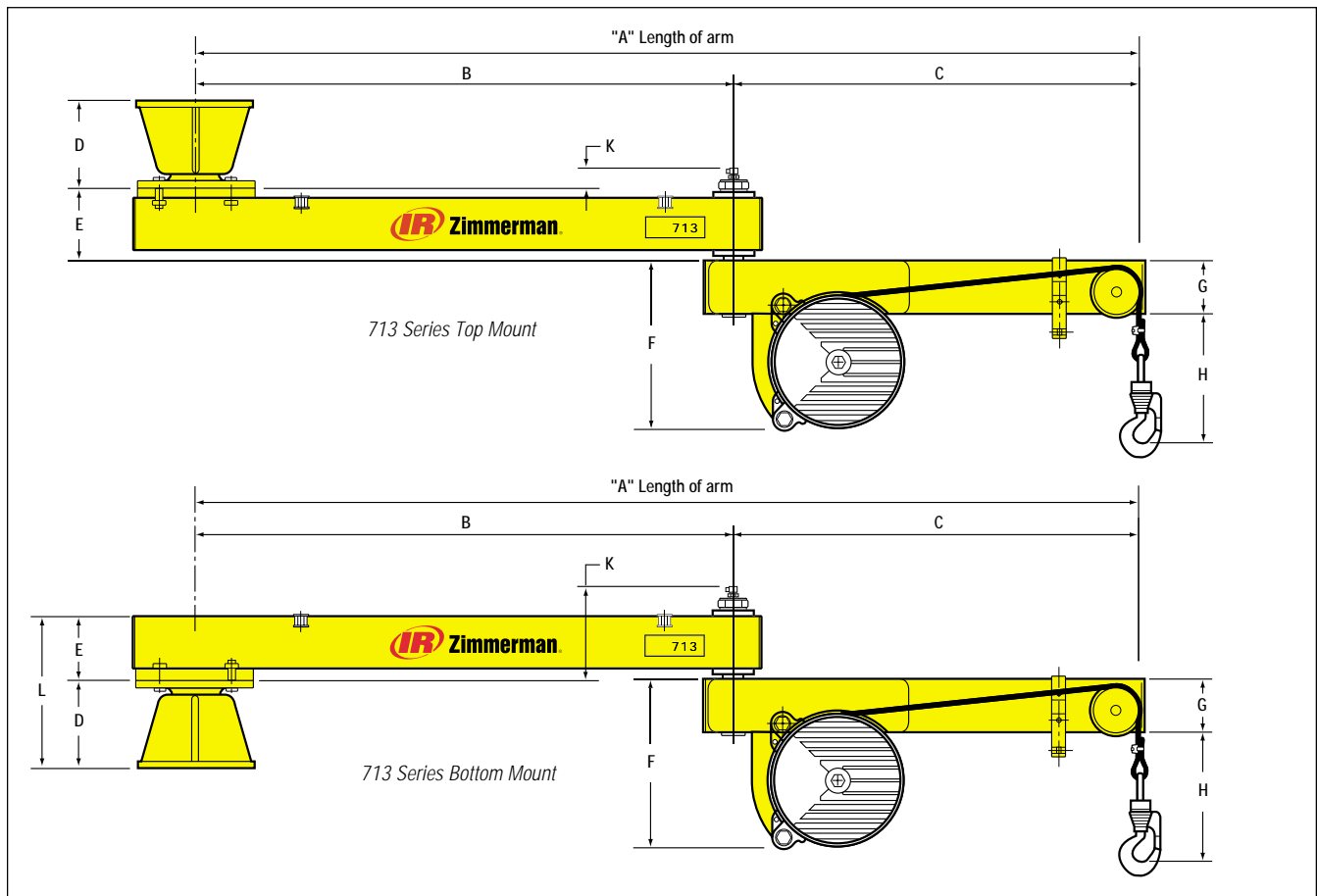

Arm Systems

Arm Systems

Series 720



Series 720 Arm						
Part No.	Arm Length		Capacity		Weight	
	ft	m	lbs	kg	lbs	kg
72015@A**?++06#	6	1.83	150	65	218	99
72015@A**?++07#	7	2.13	150	65	237	108
72015@A**?++08#	8	2.44	150	65	248	113
72015@A**?++09#	9	2.74	150	65	263	120
72015@A**?++10#	10	3.05	150	65	275	125

Series 720 Arm - Dimensions (inches)										
Capacity (lbs)	Top mt									Bottom mt
	A	B	C	D	F	G	H	L	E	
150	72	41	31	6.78	7.8	3	16.5	11.53	5.46	4.75
150	84	47	37	6.78	7.8	3	16.5	11.53	5.46	4.75
150	96	53	43	6.78	7.8	3	16.5	11.53	5.46	4.75
150	108	59	49	6.78	7.8	3	16.5	11.53	5.46	4.75
150	120	65	55	6.78	7.8	3	16.5	11.53	5.46	4.75

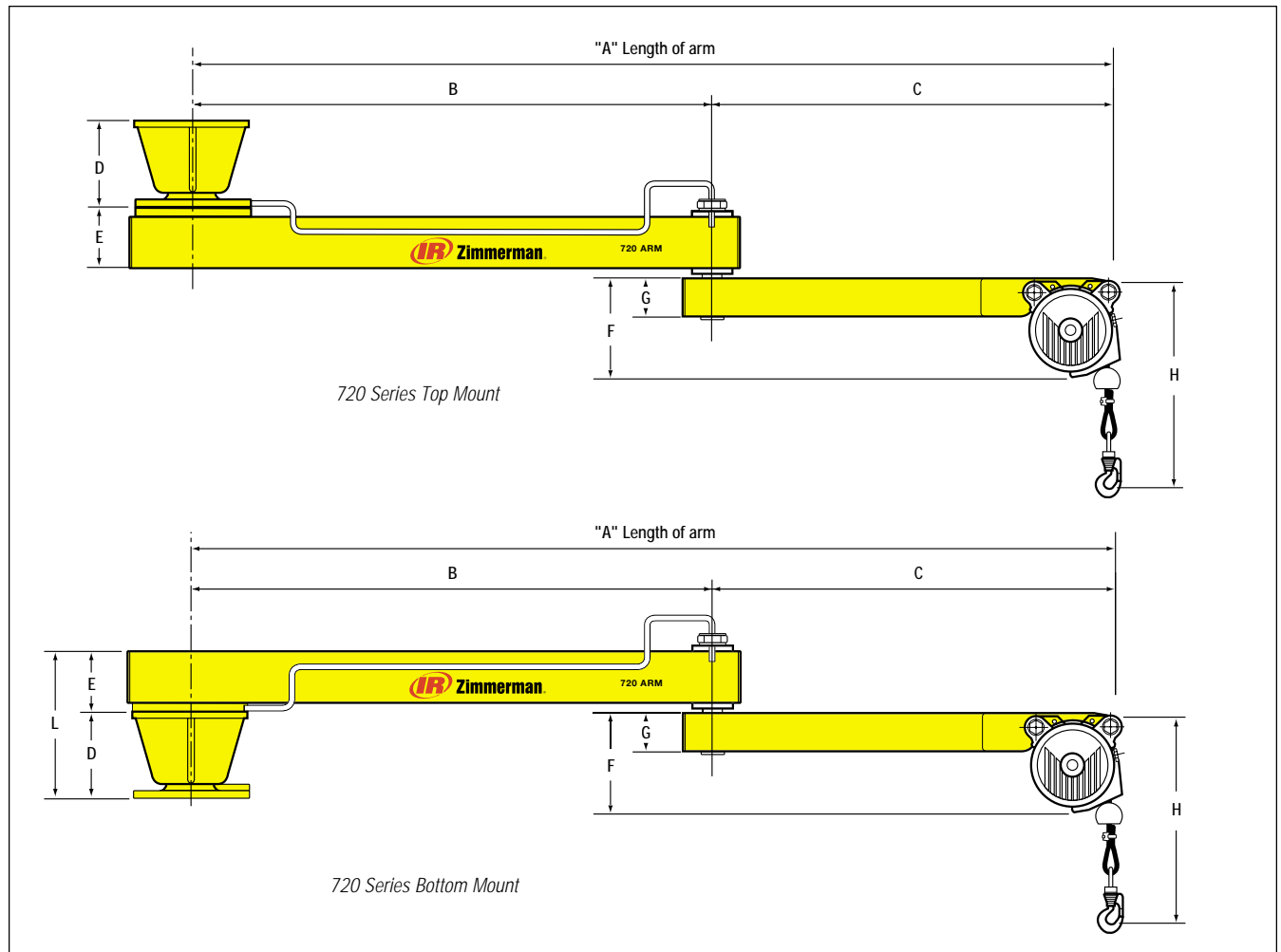

700 Arm Column Selection Chart

	Column Height in Feet (inches)					
	8' (96")	8' 6" (102")	9' (108")	10' (120")	11' (132")	12' (144")
150 lb Balancer						
6 ft Arm	54039110	54039128	54039136	54039144	54039151	54039169
7 ft Arm	54039110	54039128	54039136	54039144	54039151	54039169
8 ft Arm	54039110	54039128	54039136	54039144	54039151	54039169
9 ft Arm	54039110	54039128	54039136	54039144	54039151	54039169
10 ft Arm	54039110	54039128	54039136	54039144	54039151	54039169
200 lb Balancer						
6 ft Arm	54039110	54039128	54039136	54039144	54039151	54039169
7 ft Arm	54039110	54039128	54039136	54039144	54039151	54039169
8 ft Arm	54039110	54039128	54039136	54039144	54039151	54039169
9 ft Arm	54039110	54039128	54039136	54039144	54039219	54039227
10 ft Arm	54039110	54039128	54039136	54039201	54039219	54039227
350 lb Balancer						
6 ft Arm	54039110	54039128	54039136	54039201	54039219	54039227
7 ft Arm	54039177	54039185	54039193	54039201	54039219	54039227
8 ft Arm	54039177	54039185	54039193	54039201	54039219	54039227
9 ft Arm	54039177	54039185	54039193	54039201	54039219	54039227
10 ft Arm	54039177	54039185	54039193	54039201	54039219	54039227
500 lb Balancer						
6 ft Arm	54039177	54039185	54039193	54039201	54039219	54039227
7 ft Arm	54039177	54039185	54039193	54039201	54039219	54039227
8 ft Arm	54039235	54039243	54039250	54039268	54039276	54039284
9 ft Arm	54039235	54039243	54039250	54039268	54039276	54039284
10 ft Arm	54039235	54039243	54039250	54039268	54039276	54039284

Note:
Use the Chart above to determine the Standard Column part number for your 700 Arm.

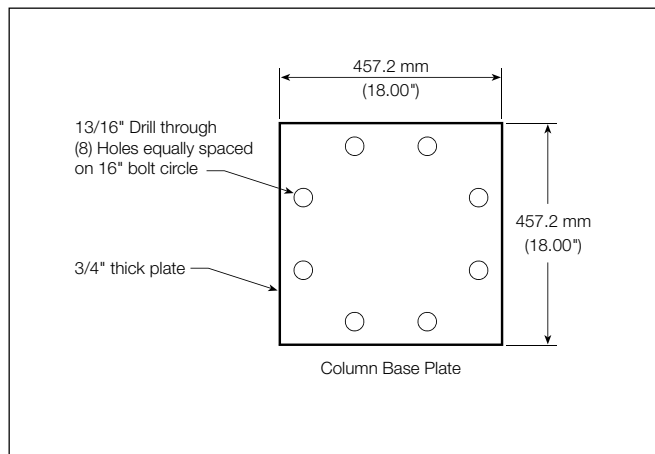

Accessories (#)

#	Description
A	Overhead Mount Column 13.12 inches tall (for use with ceiling mounted arms)
B	Column, 8 feet tall
C	Column, 8 feet 6 inches tall
D	Column, 9 feet tall
E	Column, 10 feet tall
F	Column, 11 feet tall
G	Column, 12 feet tall

Note:
Refer to 700 Arm Column Selection Chart for sizing data and part numbers.

Carriages (**)

**	Description	Part No.
NT	Carriage-Basic, no trolleys	40710
TR	Carriage Assembly - T-Rail / I-Beam	40709
A2	Carriage Assembly - ZRA2 (reaction trolley)	30028-1
S2	Carriage Assembly - ZRS2 / ZRS3	30028-2
A1	Carriage Assembly - ZRA1	30028-3
E8	Carriage Assembly - ETA-8 (reaction trolley)	30028-4
K2	Carriage Assembly - KBK2	30028-5

Notes:
Lightweight ALMAG casting. Basic carriage weighs 60.0 lbs (27.3 kg)
Each Carriage Ass'y drawing has info for both Hi & Low Profile Assemblies.

Controls (++)

++	Description
ZP	ZA (Zim-Air) Pendant control
ZQ	ZA (Zim-Air) Quad-Coil
ZT	ZA (Zim-Air) Tri-Coil
BA	BA (Balance-Air) Standard
BZ	BA (Balance-Air) Z-Servo
EP	EA (Equi-Air) 2PS Pressure
EV	EA (Equi-Air) 2PS Vacuum

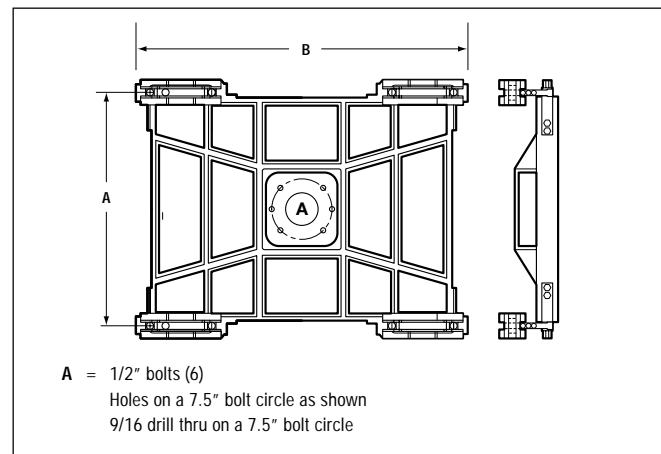

How to Order



Series 700 Arm

Example: 70015SATT0ZP06A

700 15 S A TT 0 ZP 06 A

Style _____

- 700
- 701 (150 lb capacity only)
- 713
- 720 (150 lb capacity only)

Capacity _____

- 15 = 150 lbs (68.2 kg) - 80 in. (2032 mm)
- 20 = 200 lbs (90.9 kg) - 120 in. (3048 mm)
- 35 = 350 lbs (159.1 kg) - 80 in. (2032 mm)
- 50 = 500 lbs (227.3 kg) - 80 in. (2032 mm)

Intelift Options (@) _____

- S = Standard Balancer
- I = Intelift Balancer (Consult factory)

Arm _____

Mounting Options ()** _____

- TT = Top Mount (Celling mount)
- BB = Bottom Mount (Column mount)
- A1 = ZRA1 Carriage Mount*
- A2 = ZRA2 Carriage Mount
- S2 = ZRS2 Carriage Mount
- TR = T-Rail Carriage Mount
- E8 = ETA-8 Carriage Mount
- K2 = KBK2 Carriage Mount

*Note: A1 Carriage Mount Option is only available for arms with 150 and 200 lbs (65 and 90 kg) capacity / 6, 7, and 8 ft (1.83, 2.13 and 2.44 m) length.

Carriage Options (?) _____

- 0 = No Carriage
- H = High-Profile Carriage
- L = Low-Profile Carriage

Controls (++) _____

- ZP = ZA (Zim-Air) Pendent Control
- ZQ = ZA (Zim-Air) Quad-Coil
- ZT = ZA (Zim-Air) Tri-Coil
- BA = BA (Balance-Air) Standard
- BZ = BA (Balance-Air) Z-Servo
- EP = EA (Equi-Air) 2PS Pressure
- EV = EA (Equi-Air) 2PS Vacuum

Arm Length _____

- 06 = 6 ft (1.83 m) Arm
- 07 = 7 ft (2.13 m) Arm
- 08 = 8 ft (2.44 m) Arm
- 09 = 9 ft (2.74 m) Arm
- 10 = 10 ft (3.05 m) Arm

Mounating Accessories (#) _____

- 0 = No Mounting Accessories
- A = 13 in. (0.33 m) Ceiling Mount
- B = 8 ft (2.44 m) Column Mount
- C = 8 ft 6 in. (2.59 m) Column Mount
- D = 9 ft (2.74 m) Column Mount
- E = 10 ft (3.05 m) Column Mount
- F = 11 ft (3.35 m) Column Mount
- G = 12 ft (3.66 m) Column Mount

Arm Systems

Series 600 Arm



Series 600 Arm - Allowable Mast Configurations

lbs	Load (L) max	Load CG (C) max		Single Mast Ht. (H) max		Max Hook Travel (V) ⁽¹⁾	
	kg	in	mm	in	mm	in	mm
Single Mast Configuration							
150	68.2	12	305	144	3658	80	2032
		24	610	144	3658	80	2032
		36	914	144	3658	80	2032
		48	1219	144	3658	80	2032
		60	1524	138	3505	80	2032
200	90.9	72	1829	114	2896	74	1880
		12	305	144	3658	104	2642
		24	610	144	3658	104	2642
		36	914	144	3658	104	2642
		48	1219	126	3200	86	2184
350	159.1	60	1524	102	2591	62	1575
		72	1829	84	2134	44	1118
		12	305	144	3658	80	2032
		24	610	144	3658	80	2032
		36	914	96	2438	56	1422
500	227.3	48	1219	72	1829	32	813
		60	1524	60	1524	20	508
		72	1829	48	1219	8	203
		12	305	144	3658	80	2032
		24	610	102	2591	62	1575
700	318.2	36	914	66	1676	26	660
		48	1219	54	1372	14	356
		12	305	138	3505	40/80	1016/2032
		24	610	72	1829	26/32	660/813
		36	914	48	1219	2/8	51/203
1000	454.5	12	305	96	2438	40/56	1016/1422
		24	610	54	1372	8/14	203/356
Dual Mast Configuration							
150	68.2	60	1524	144	3658	80	2032
		72	1829	144	3658	80	2032
200	90.9	48	1219	144	3658	104	2642
		60	1524	144	3658	104	2642
350	159.1	72	1829	144	3658	104	2642
		36	914	144	3658	80	2032
		48	1219	144	3658	80	2032
500	227.3	60	1524	120	3048	80	2032
		72	1829	102	2591	62	1575
		24	610	144	3658	80	2032
700	318.2	36	914	144	3658	80	2032
		48	1219	144	3658	80	2032
		12	305	144	3658	40/80	1016/2032
1000	454.5	24	610	144	3658	40/80	1016/2032
		36	914	102	2591	40/62	1016/1575
1000	454.5	12	305	144	3658	40/80	1016/2032
		24	610	108	2743	40/68	1016/1727



600 Arm shown with optional probe

Series 600 Arm - Mast Configurations

Part No.	Capacity		Max. Travel		Notes
	lbs	kg	in	mm	
Single Mast Configuration					
60015@A1**+&#	150	68.2	80	2032	1x Balancer
60020@A1**+&#	200	90.9	120	3048	1x Balancer
60035@A1**+&#	350	159.1	80	2032	1x Balancer
60050@A1**+&#	500	227.3	80	2032	1x Balancer
6007R@A1**+&#	700	318.2	40	1016	1x Bal. (reeved)
6007T@A1**+&#	700	318.2	80	2032	2x Balancer
6001R@A1**+&#	1000	454.5	40	1016	1x Bal. (reeved)
6001T@A1**+&#	1000	454.5	80	2032	2x Balancer
Dual Mast Configurations					
60015@A2**+&#	150	68.2	80	2032	1x Balancer
60020@A2**+&#	200	90.9	120	3048	1x Balancer
60035@A2**+&#	350	159.1	80	2032	1x Balancer
60050@A2**+&#	500	227.3	80	2032	1x Balancer
6007R@A2**+&#	700	318.2	40	1016	1x Bal. (reeved)
6007T@A2**+&#	700	318.2	80	2032	2x Balancer
6001R@A2**+&#	1000	454.5	40	1016	1x Bal. (reeved)
6001T@A2**+&#	1000	454.5	80	2032	2x Balancer

Arm Systems

Series 600 Arm



Vertical Travel of Balancer (Q) VS. Mast Height (H) - 32 in (812mm)

Balancer Capacity		Vertical Travel (Q)		Notes
lbs	kg	in	mm	
150	68.2	80	2032	1 x Balancer
200	90.9	120	3048	1 x Balancer
350	159.1	80	2032	1 x Balancer
500	227.3	80	2032	1 x Balancer
700 ⁽¹⁾	318.2	40	1016	1 x Balancer (reeved)
700 ⁽²⁾	318.2	80	2032	2 x Balancer
1000 ⁽¹⁾	454.5	40	1016	1 x Balancer (reeved)
1000 ⁽²⁾	454.5	80	2032	2 x Balancer

Notes:

- (1) = 1 Balancers Reeved
- (2) = 2 Balancers Tandem

Series 600 Arm - Mast Configurations

Part No.	Arm Sub-Assy No.	Balancer Part No.
Single Mast Configuration		
60015@A1**+&#	54039649	BW015080000
60020@A1**+&#	54039664	BW020120S00
60035@A1**+&#	54039664	BW035080S00
60050@A1**+&#	54039664	BW050080S00
6007R@A1**+&#	54039664	BW070040S00
6007T@A1**+&#	54039680	BW070080S00
6001R@A1**+&#	54039664	BW100040S00
6001T@A1**+&#	54039680	BW100080S00
Dual Mast Configuration		
60015@A2**+&#	54039656	BW015080000
60020@A2**+&#	54039672	BW020120S00
60035@A2**+&#	54039672	BW035080S00
60050@A2**+&#	54039672	BW050080S00
6007R@A2**+&#	54039672	BW070040S00
6007T@A2**+&#	54039698	BW070080S00
6001R@A2**+&#	54039672	BW100040S00
6001T@A2**+&#	54039698	BW100080S00

Carriages (**)

**	Description	Stack-up ⁽¹⁾ (CS)	Part No.
NT	Carriage-Basic, no trolleys		40710
TR	Carriage - T-Rail / I-Beam	5.46	40709
A2	Carriage - ZRA2 (reaction trolley)	5.97	30028-1
S2	Carriage - ZRS2 / ZRS3	5.97	30028-2
A1	Carriage - ZRA1	8.44	30028-3
E8	Carriage - ETA-8 (reaction trolley)	7.16	30028-4
K2	Carriage - KBK2	5.97	30028-5

Note:

- Lightweight ALMAG casting. Carriage weighs 60.0 lbs (27.3 kg)
- (1) Dimension is from the rail running surface to the base of the pivot. Changes with brake option.

Controls (+)

+	Description	Controls Sub-Assembly No.	
		1x Mast	2x Mast
Z	ZA (Zim-Air) Control	54039847	54039854

Brake Options (&)

&	Description	Part No.
0	No brake	-
P	Pin-lock Brake (hard stops every 45 degrees)	54039722
B	Bumper Friction Brake	54039730
C	Caliper Brake	54040977

Masts (#)

#	Description	Part No.
A	ZRA2 Mast, 4' [1.22 m] Long	30000-040-2
B	ZRA2 Mast, 4' 6" [1.37 m] Long	30000-045-2
C	ZRA2 Mast, 5' [1.52 m] Long	30000-050-2
D	ZRA2 Mast, 5' 6" [1.68 m] Long	30000-055-2
E	ZRA2 Mast, 6' [1.83 m] Long	30000-060-2
F	ZRA2 Mast, 6' 6" [1.98 m] Long	30000-065-2
G	ZRA2 Mast, 7' [2.13 m] Long	30000-070-2
H	ZRA2 Mast, 7' 6" [2.29 m] Long	30000-075-2
J	ZRA2 Mast, 8' [2.44 m] Long	30000-080-2
K	ZRA2 Mast, 8' 6" [2.59 m] Long	30000-085-2
M	ZRA2 Mast, 9' [2.74 m] Long	30000-090-2
N	ZRA2 Mast, 9' 6" [2.90 m] Long	30000-095-2
P	ZRA2 Mast, 10' [3.05 m] Long	30000-100-2
Q	ZRA2 Mast, 10' 6" [3.20 m] Long	30000-105-2
R	ZRA2 Mast, 11' [3.35 m] Long	30000-110-2
S	ZRA2 Mast, 11' 6" [3.51 m] Long	30000-115-2
T	ZRA2 Mast, 12' [3.66 m] Long	30000-120-2

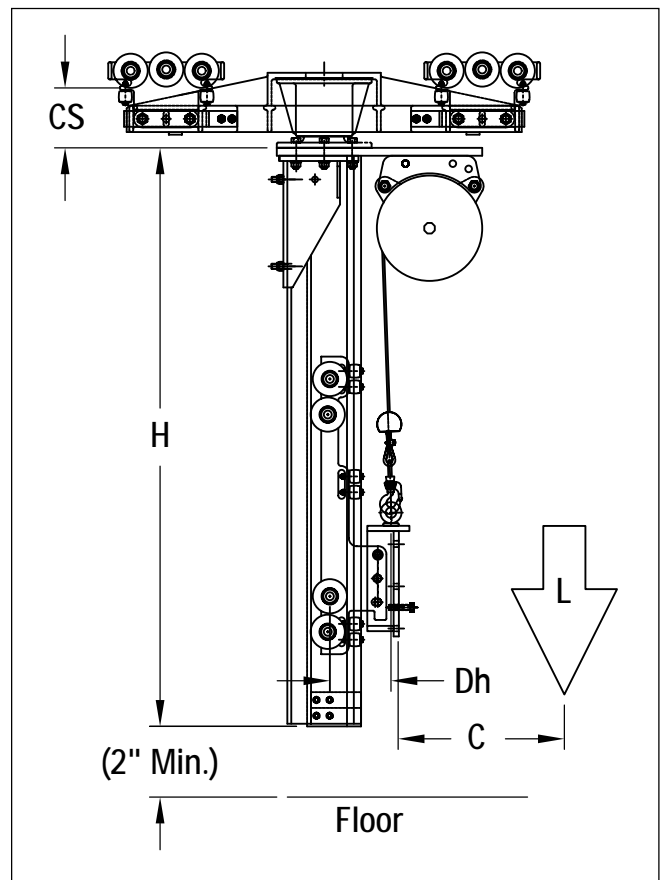

How to Order



Series 600 Arms

Example: 60015IA1A2ZPG

600 15 I A 1 A2 Z P G

Style _____

600

Capacity - Vertical Travel _____

- 15 = 150 lbs (68.2 kg) - 80 in. (2032 mm)
- 20 = 200 lbs (90.9 kg) - 120 in. (3048 mm)
- 35 = 350 lbs (159.1 kg) - 80 in. (2032 mm)
- 50 = 500 lbs (227.3 kg) - 80 in. (2032 mm)
- 7R = 700 lbs (318.2 kg) - 40 in. (1016 mm)
- 7T = 700 lbs (318.2 kg) - 80 in. (2032 mm)
- 1R = 1000 lbs (454.5 kg) - 40 in. (1016 mm)
- 1T = 1000 lbs (454.5 kg) - 80 in. (2032 mm)

Intelift Options (@) _____

- S = Standard Balancer
- I = Intelift Balancer (Consult factory)

Arm _____

Single or Dual Mast _____

- 1 = Single Mast
- 2 = Dual Mast

Carriage Options (***) _____

- A1 = ZRA1
- A2 = ZRA2
- S2 = ZRS2
- S3 = ZRS3
- TR = T-Rail
- E8 = ETA-8
- K2 = KBK2

Note: All Zimmerman 600 Arms use a Low Profile Carriage Assembly

Controls (+) _____

- Z = ZA (Zim-Air) Control (Includes dummy handle)

Brake Options (&) _____

- O = No brake
- P = Pin-lock Brake (hard stops every 45 degrees)
- B = Bumper Friction Brake (soft stop at any point on 360 degree rotation)
- C = Caliper Brake

Mast Length (#) _____

- | | | |
|-------------------------|-------------------------|--------------------------|
| A = 4 ft (1.22 m) | G = 7 ft (2.13 m) | P = 10 ft (3.05 m) |
| B = 4 ft 6 in. (1.37 m) | H = 7 ft 6 in. (2.29 m) | Q = 10 ft 6 in. (3.20 m) |
| C = 5 ft (1.52 m) | J = 8 ft (2.44 m) | R = 11 ft (3.35 m) |
| D = 5 ft 6 in. (1.68 m) | K = 8 ft 6 in. (2.59 m) | S = 11 ft 6 in. (3.51 m) |
| E = 6 ft (1.83 m) | M = 9 ft (2.59 m) | T = 12 ft (3.66 m) |
| F = 6 ft 6 in. (1.98 m) | N = 9 ft 6 in. (2.90 m) | |

Lifting and Positioning Systems

IR Zimmerman has over 40 years of experience in custom designed material handling systems. With many innovations in the design of handling devices to our credit, we offer a complete range of end effectors from the simplest to the most complex device. In every respect IR Zimmerman is an essential part of a more productive ergonomic work place, empowering individuals to work more comfortably and effectively.



IR Zimmerman provided material handling solutions to Thermo King® in handling the back panel for a refrigeration unit. The handling device includes a Power Tilt feature.



Safety

Most IR Zimmerman End Effectors come equipped with a Safety Interlock system that will not allow the operator to accidentally disengage the part during transfer.



**Call 1-800-347-7047
for distributors in your area**



Flexibility



Safety



Ergonomics



Productivity



Cost Savings



IR Zimmerman Material Handling Products in a clean room high tech environment application.



Flexibility
Through a variety of pneumatic packages each system is matched to a control package that is tailored to the lifting and positioning task.



The spool handling device shown here used by a major pharmaceutical products manufacturer, has Dual Controls. The spools are stacked 3-high in a box and the Dual Controls enable the operator to pick up spools without bending.



Air clamp handling device for engine rollover



Tire handling device with 90 degree manual rotate.



Vacuum end effector integrated with 4 Ingersoll-Rand D-Series nut runners shown installing a lift gate assembly.



Clamp handling device with 90 degree power tilt shown handling an alternator.

- e **Ergonomics**
 End Effectors can be designed with manual and/or powered tilt and rotation packages, which allow the operator to orient the part to the proper position with minimal effort.

**Call 1-800-347-7047
for distributors in your area**



IR Zimmerman pioneered the development of pneumatic powered lifting and balancing equipment, making us a world leader in the manufacture of ergonomic, in-process, manual assist, pick and place systems. With over 40 years of experience in providing ergonomic lifting systems for the converting (Paper, Film, & Foil) and packaging industries, we have a solution to fit your needs. We specialize in providing turn-key solutions utilizing our complete line of standard and custom products to create a combination that meets your needs.

Rotary Action Handler

- 90 degree manual rotation of rolls.
- Cast aluminum construction for light weight.
- Rubber band (non-destructive) and pin style noses engage the I.D. of the core.
- Optional side clamp to prevent telescoping of rolls.
- Safety interlock to prevent operator from releasing the load during transfer.



75 lb copper coil used in refrigeration container units with 90 degree rotate from Thermo King®



Power-Tilt Roll Handling Device

- Powered 90 degree rotation.
- Multiple sizes, up to 500 lb rolls.
- Rubber band (non-destructive) and pin style noses engage the I.D. of the core.
- Optional shifting center of gravity.
- Optional side clamp to prevent telescoping of rolls.
- Safety interlock to prevent operator from releasing the load during transfer.



Nondestructive nose



Nondestructive step nose

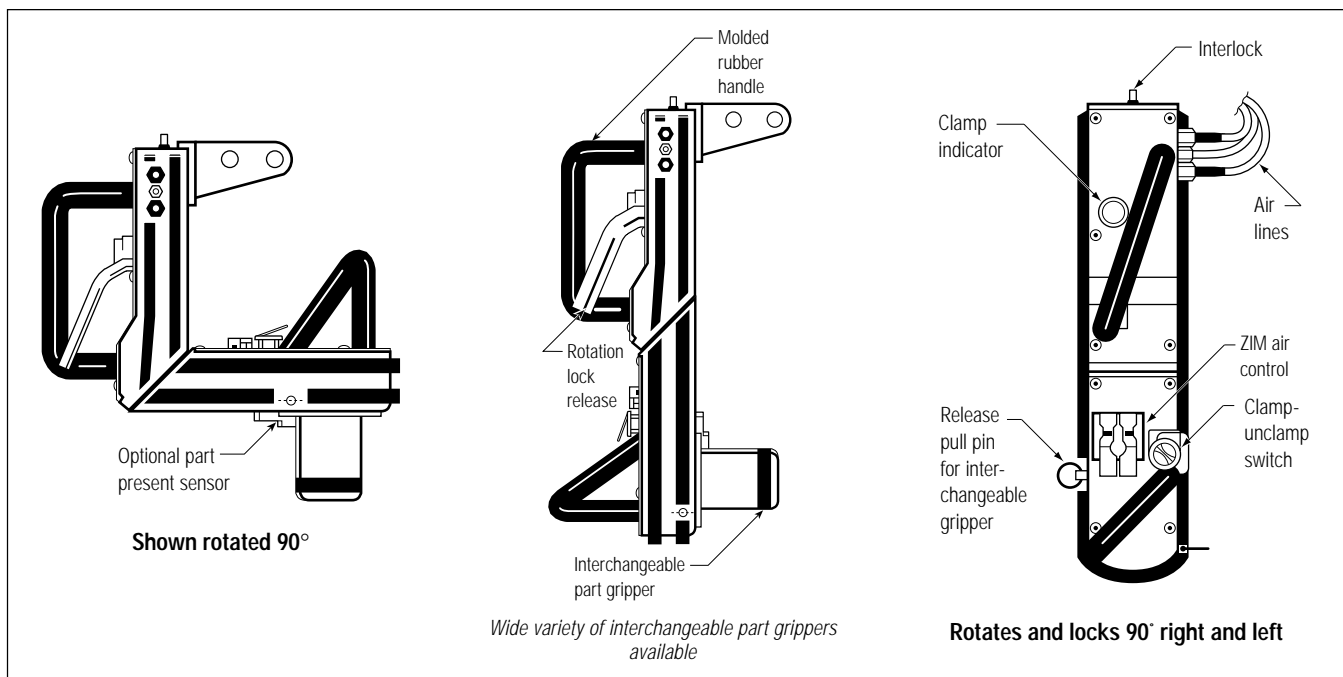

With over 40 years of experience in providing ergonomic lifting systems for the Printing industry, we have a solution to fit your application. Whether in the pressroom or the bindery we have a solution to meet your signature log handling needs. We specialize in providing complete turn-key solutions utilizing our complete line of standard and custom products to create a combination that meets your needs.

Signature Bundle Handler SBH-1

- Single stroke air cylinder with 900 lbs clamping force at 90 psig.
- Safety interlock to prevent operator from releasing the load during transfer.
- Straight transfer.
- Handles up to 250 lb bundles.
- Standard paddles for end boards, (6 x 9" through 12 x 12").
- 10 inches of clamp range available, minimum log size, (24").
- Light weight aluminum construction.



Signature Bundle Handler SBH-2

- Dual stroke cylinder for greater opening.
- Safety interlock to prevent operator from releasing the load during transfer.
- Straight transfer.
- Handles up to 300 lb bundles.
- Up to 30 inches of stroke, minimum log size, (20"), maximum of (50").

Signature Bundle Handler SBH-2P

- Same standard features as SBH-2.
- Safety interlock to prevent operator from releasing the load during transfer.
- Self-retracting leveling pad for positioning.
- Power rotate 90 or 180 degrees.
- Extended paddles available.



Parallel Torque Arms



Features/Benefits

- Air Bias Support System Air Adjustment by mini-regulator with air cylinder, for proper positioning of different size tools. Eliminates the clumsy spring adjustment of competitive models. Tool positioning is effortless.
- Parallel Arm Torque Absorber Absorbs torque reaction up to 120 in. lbs. Increases torque repeatability through shift changes by reducing operator influence on fastener. Keeps tools off the floor.
- Steel & Aluminum Construction Anodized finish Lightweight Heavy duty for high volume production Corrosion resistant.
- Auto-Orientation System Tool fixture is designed to allow constant perpendicular orientation of the tool, which ensures proper fastener alignment.

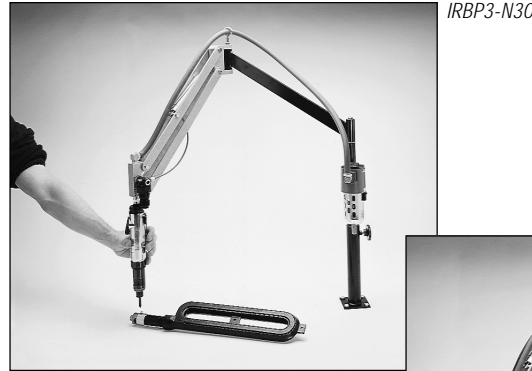

Accessories

- 48732-1 Bench clamp for mounting arm in place
- C10-02-000 Filter/Lubricator (1/4")
- R00-02-G00 Regulator (1/4")
- IR49541 Swivel Mount Kit Grip and Angle Tools (adapts pistol to the workstation)

Parallel Torque Arms			
Model no.	Length (in.)	Tool use	Torque absorber
IRBP3-N30	30	Air	Yes
IRBP3-E30	30	Electric	Yes

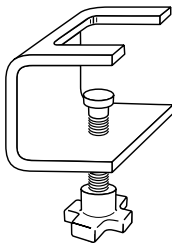

48732-1

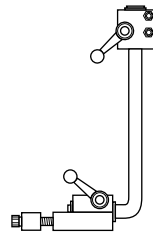

IR49541



Filter/Regulator (1/4 in.)
B18-02-FKG0-28



Lubricator (1/4 in.)
L18-02-LK00-28

Dimensions

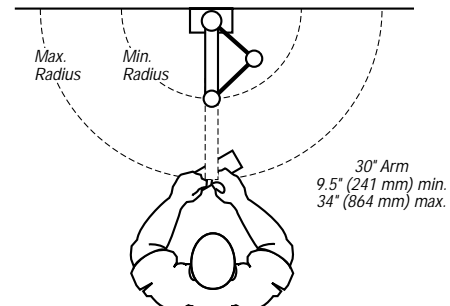
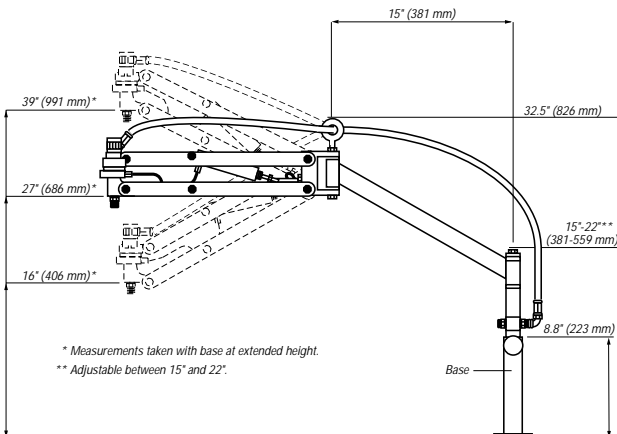

Features/Benefits

- Steel Construction: E-Coat Lightweight but durable for continuous duty. Corrosion Resistant.
- Flexible: Your choice of 30" or 24" lengths for electric or air tools.
- Balancer Hanger: All arms are equipped with a roller mounted balancer hanger for smooth motion of the tool.
- Electric Cord Clamp Kit: Standard with appropriate models.

Options

- Single Arm Torque Absorber: Telescoping torque arm improves flexibility. Eliminates torque reaction from the tool.

Accessories

- Balancers – Choice of balancers
7/8 to 2-1/4 lbs Bld 1
2 to 4 lbs = Bld 2
4 to 6 lbs = Bld 3
- 48732-1 Bench clamp for mounting arm in place
- C10-02-000 Filter/Lubricator (1/4")
- R00-02-G00 Regulator (1/4")



IRBS3-N30 (Hose, FRL and balancer not included)



IRBS3-E0

Parallel Torque Arms			
Model no.	Length (in.)	Tool use	Torque absorber
IRBS2-N0	24	Air	No
IRBS2-N24	24	Air	Yes
IRBS2-E0	24	Electric	No
IRBS2-N24	24	Electric	Yes
IRBS3-N0	30	Air	No
IRBS3-N30	30	Air	Yes
IRBS3-E0	30	Electric	No
IRBS3-E30	30	Electric	Yes

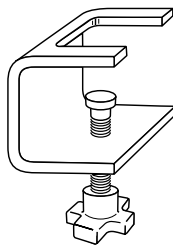

48732-1

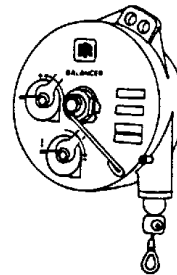

IRAX Balancer



Filter/Regulator (1/4 in.)
B18-02-FKG0-28



Lubricator (1/4 in.)
L18-02-LK00-28

Dimensions

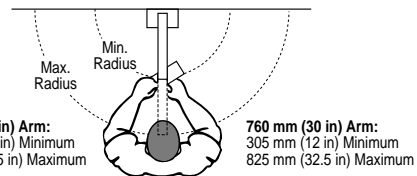
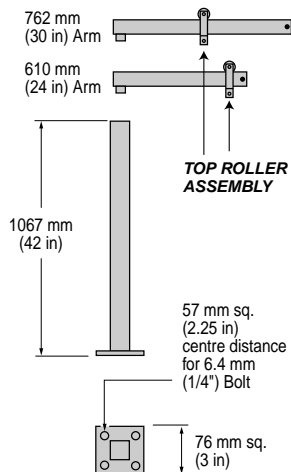

Beam Clamp

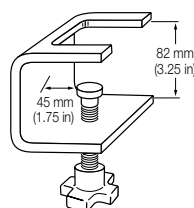

Electric Tool Clamp

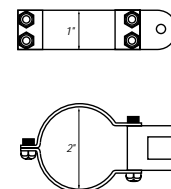

EZ Tool Articulating Arm



EZ tool arm features:

- Covers a 610 x 762 mm (24 x 30 inch) horizontal rectangular work envelope.
- Two piece arm with overall length adjustable from 864 to 1067 mm (34 to 42 inches).
- Anodized aluminum construction.
- Mounting plates attach vertically or horizontally.
- First portion of the arm consists of two adjustable sections connected to the mounting plate by a 360 degree pivot.
- Second, outer portion of the arm is a dual parallel arm design that allows for 500 mm (20 inches) of vertical travel, and is connected to the first portion by a 360 degree pivot.

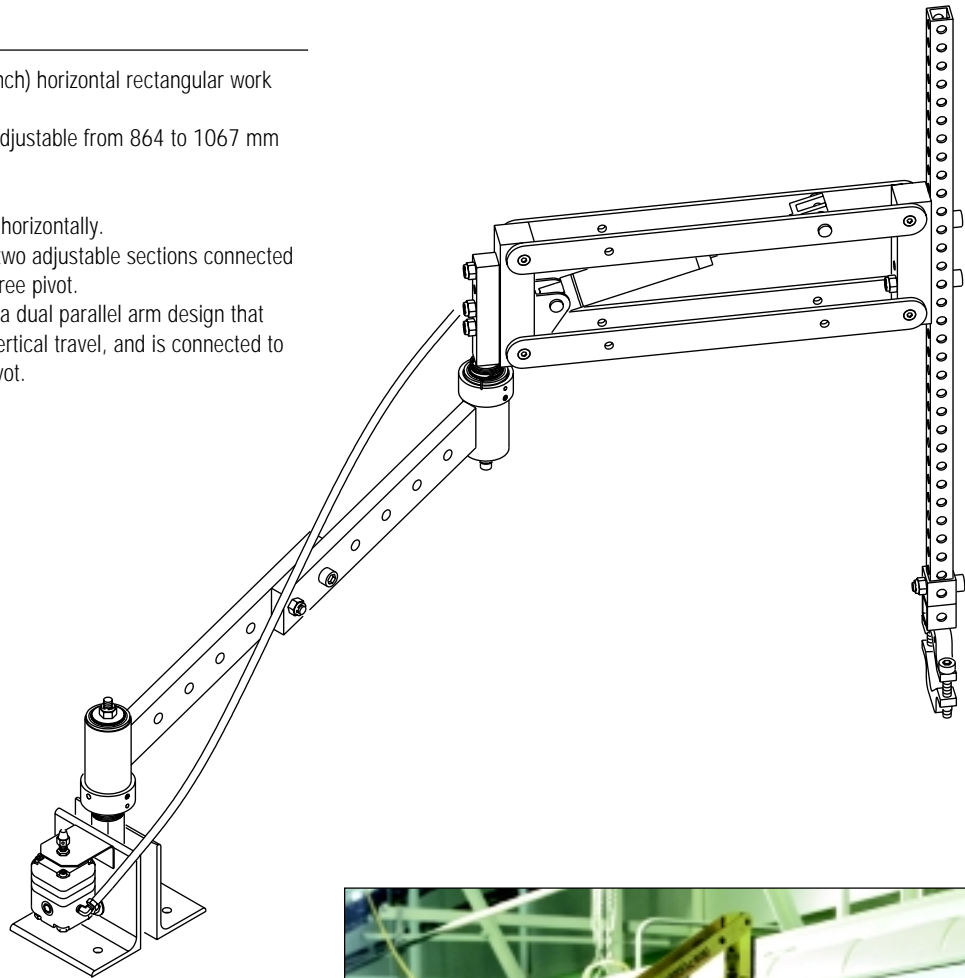

Additional features:

- Each pivot contains roller bearings for smooth operation and an adjustable pivot spring to return the arm to a "home" position.
- Capacity is 13.6 kg (30 lb) at 7 bar (100 psi).
- Pneumatics control system consists of a single precision pneumatic regulator to allow balance of the end of the arm. Maximum torque reaction is 80 Nm (60 ft/lb).
- Fixed tool holder to handle tool diameter from 13 to 63.5 mm (.50 to 2.5 inches) is adjustable for vertical or horizontal tool orientation.



EZ Tool Arm in an assembly process

EZ Tool Articulating Arm Specifications

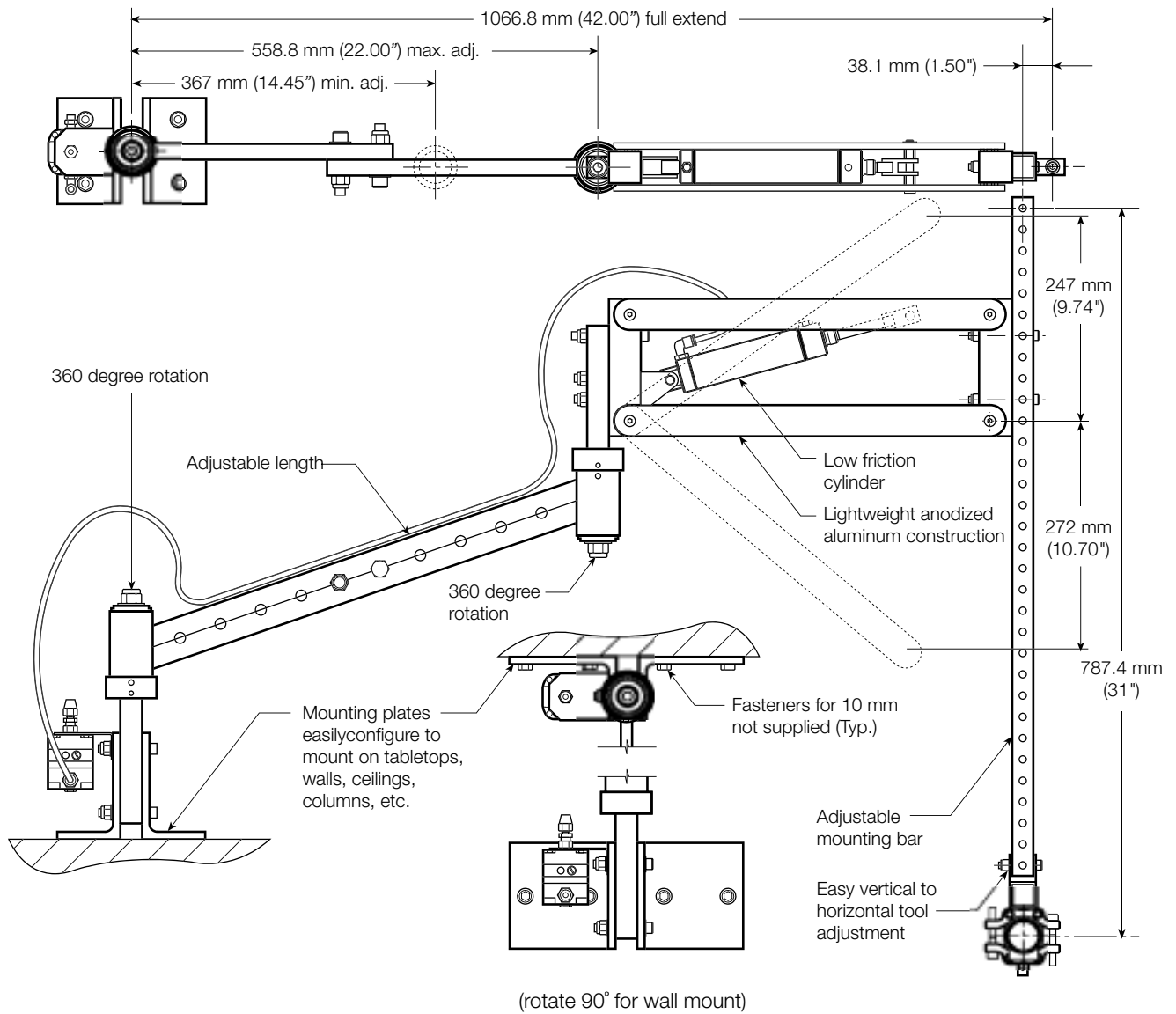

EZ tool arm model number EZTA080500 illustrated



Tool Holders

Part no.	Description
54033162	Bi-Directional tilt / Push to start tool
54033196	Single-Directional tilt tool holder

EZ Tool Arm

Part no.	Description
EZTA080500	Light weight torque arm with tool holder
43146000	Light weight articulating arm without tool holder

E-Z Torque



Just as the name indicates, the new IR Zimmerman E-Z Torque® has taken the struggle out of using hand-held torque tools.

The lightweight E-Z Torque has been coupled with our 50 pound Balancer to provide the most innovative power tool assist system available today. Ease of operation eliminates operator fatigue problems, fights carpal tunnel syndrome and brings added safety to the workstation. E-Z Torque has been engineered to absorb the pounding reaction of air-powered or electric-driven torque tools. Constructed of cast aluminum and steel with ball bearing rollers and a 48 inch (1219.2 mm) vertical travel, the E-Z Torque eliminates spring pull back and maintains tool position with no problem.

Features:

- Lightweight torque tool assist
- Ease of operation
- Reduces operator fatigue
- Aluminum and steel construction
- Adjustable to fit any tool

E-Z Torque	
Part no. complete	Application
EZTQ5060	EZ Torque Tool Balancer
Suspension Kits	
16520	ZRA1 rail
16525	ZRA2 rail
16530	ZRS2/3 rail

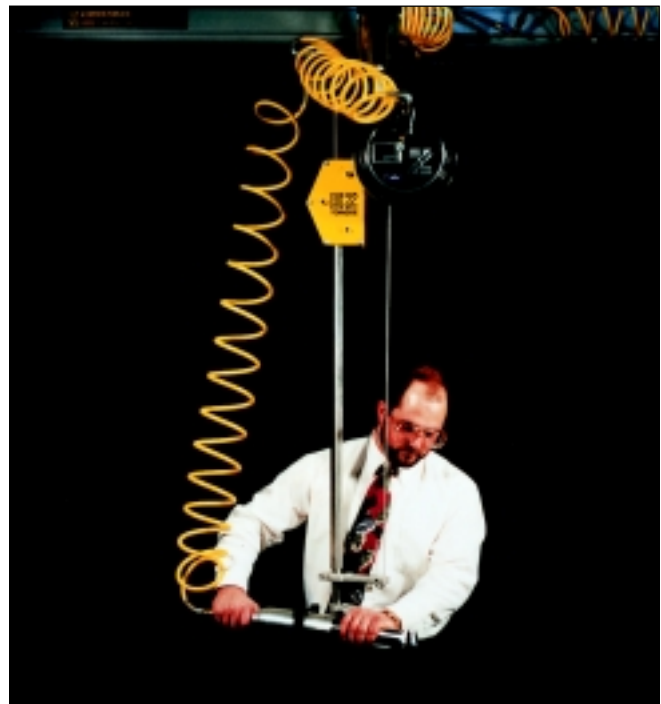

E-Z Torque shown with optional tool

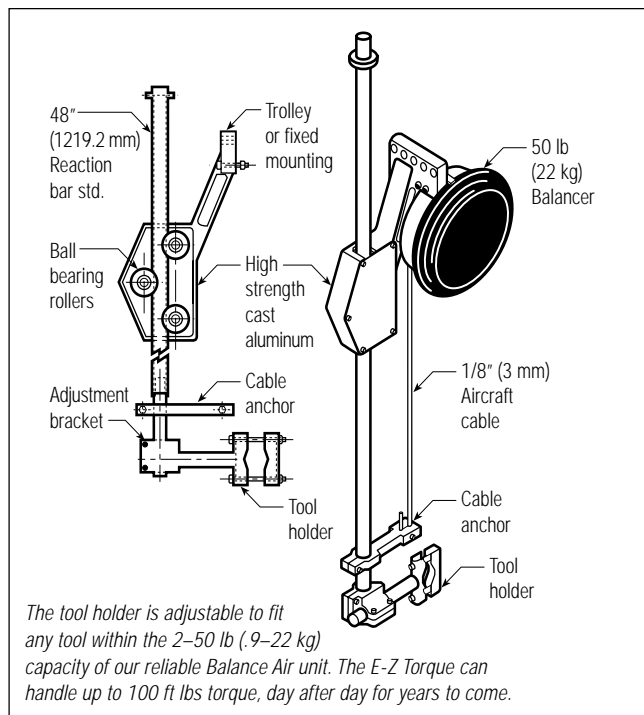

Torque Tube

We at IR Zimmerman support our tool product line with ergonomic torque reaction and tool suspension products to assist in reducing operator fatigue. Our products relieve the operator of tool weight and torque resulting in productivity. These products also help prevent the long-term damaging effects of torque reaction on the human body, resulting in lower workers compensation and health care costs.

Our torque tubes allow tools to be lifted, lowered, moved and brought into optimum working position with minimal force required by the operator. Whether the products are used alone or integrated into a larger "turnkey" system, the smooth and effortless vertical motion will be the perfect solution for various operators.

The availability of various sizes and the modularity of design allows System Integrators to use individual component parts without having to purchase complete units.

Modular Components

Suspension kit features:

- High strength Delrin wheels
- Cast aluminum or stamped steel trolley bodies
- Sealed bearings
- Low tolerance side guide rollers

Torque tube features:

- 0 - 150 Nm torque capacity
- Modular metric design
- Low friction bearing plates for effortless vertical travel and maintenance-free operation
- 304 stainless steel construction
- 20 kg/44 lb capacity at 7 bar/100 psi
- 300, 600, 900 mm/12, 24, 36 inches of vertical travel

Extension tube features:

- Rugged welded stainless steel construction

Tool holder features:

- Tool holder clamp is 316 stainless steel construction designed to minimize tool damage
- Accepts tools of 19 mm to 63 mm/.75 to 2.5 in. diameter
- Switches easily from horizontal to vertical orientation
- 360 degree tool holder features:
- Generous 66.8 mm/2.63 in. opening insures that tool head does not have to be removed for quick changes
- Bronze bushing provides easy rotation and durability
- Rotates freely through 360 degrees or locks at 45 degree increments with indexing plunger

Air cylinder features:

- Low friction cylinders
- High flow regulator

Tool air supply features:

- Precoil hoses
- Bulkhead fittings

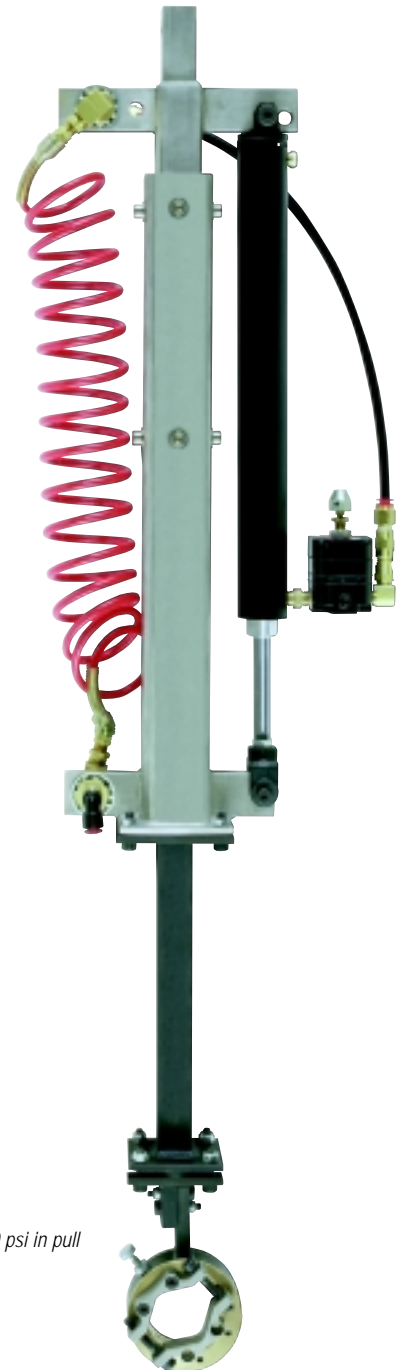

1.5 inch bore cylinder @ 100 psi in pull
with lift, 100 lbs/45 kg

Torque Tube Components

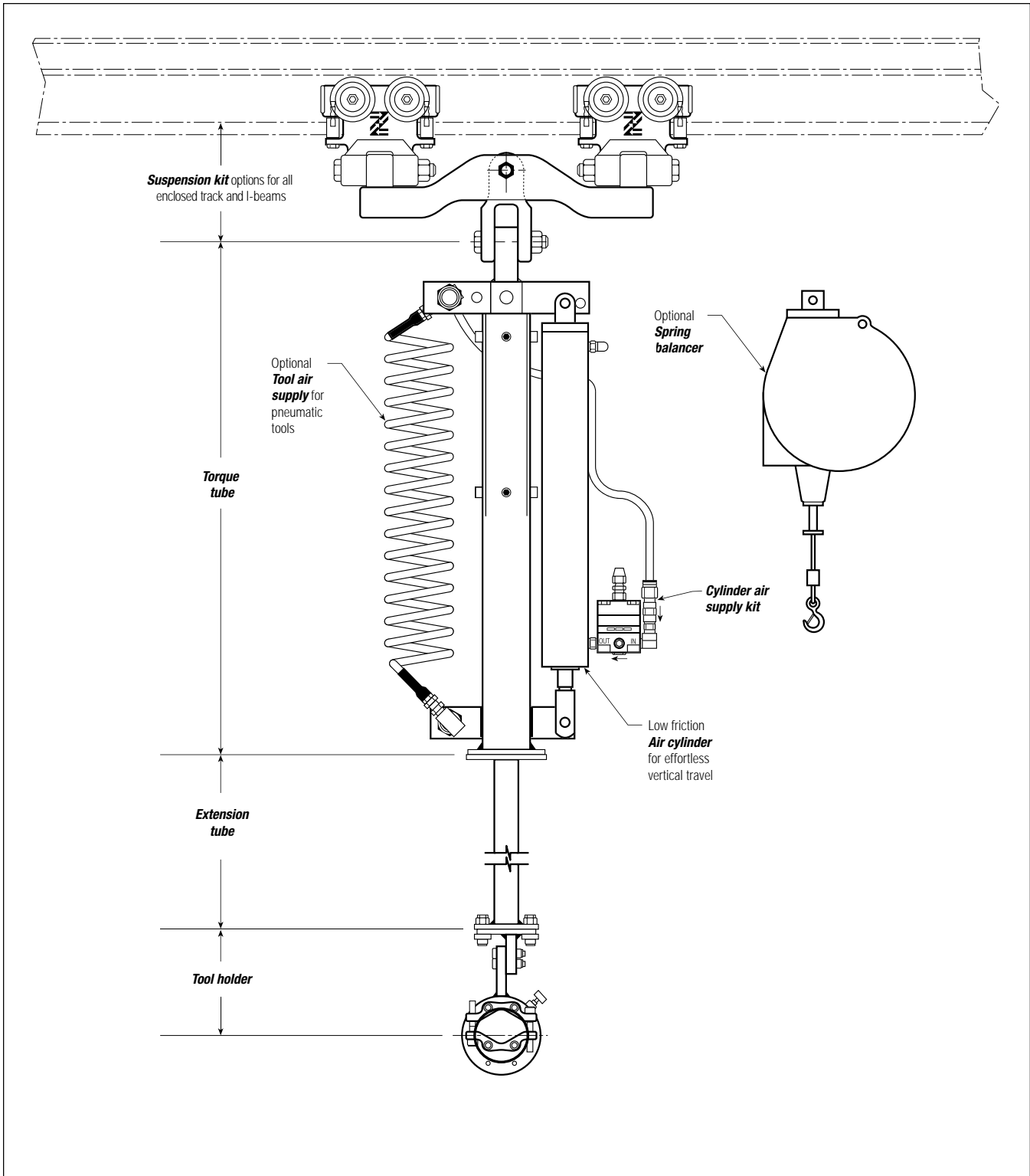

Suspension kit features:

- High strength Delrin wheels
- Cast aluminum or stamped steel trolley bodies
- Sealed bearings
- Special low tolerance side guide rollers

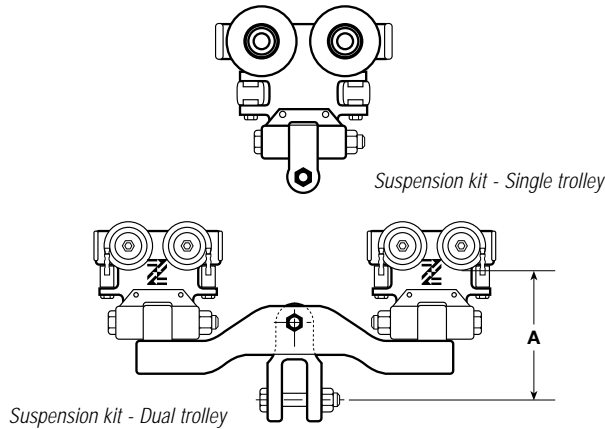

Suspension Kits – Single and Dual Trolleys

Model no. Dual trolley ⁽¹⁾	Part No.	"A" dimension		Weight	
		in.	mm	lbs	kg
Single					
ZRA2	16610	4.75	120	4.50	2
ZRAS2/3	16600	4.75	120	4.50	2
KBK-II/III	16615	4.75	120	4.50	2
ETA-8	16635	4.75	120	4.50	2
T-Rail	16620	3	76.2	15	6.8
Dual					
ZRAT	16755	6.48	165.0	10.50	4.76
ZRA1	16705	6.13	156.0	10.50	4.76
ZRA2	16710	6.76	172.0	10.50	4.76
ZRAS2/3	16700	6.76	172.0	10.50	4.76
KBK-I	16725	6.13	156.0	10.50	4.76
KBK-II/III	16715	6.76	172.0	10.50	4.76
ETA-4	16744	6.13	156.0	10.50	4.76
ETA-8	16735	6.76	172.0	10.50	4.76
Gorbel	16707	6.13	156.0	10.50	4.76
T-Rail	16620	3.00	76.2	15.00	6.8

Tool air supply features:

- Precoil hoses
- Bulkhead fittings



Tool Air Supply

Part no.	Description
90014	Tool air supply package 1/4 inch
90012	Tool air supply package 1/2 inch

Torque tube features:

- Low friction bearing plates for effortless vertical travel and maintenance-free operation
- stainless steel construction
- Modular metric worldwide design

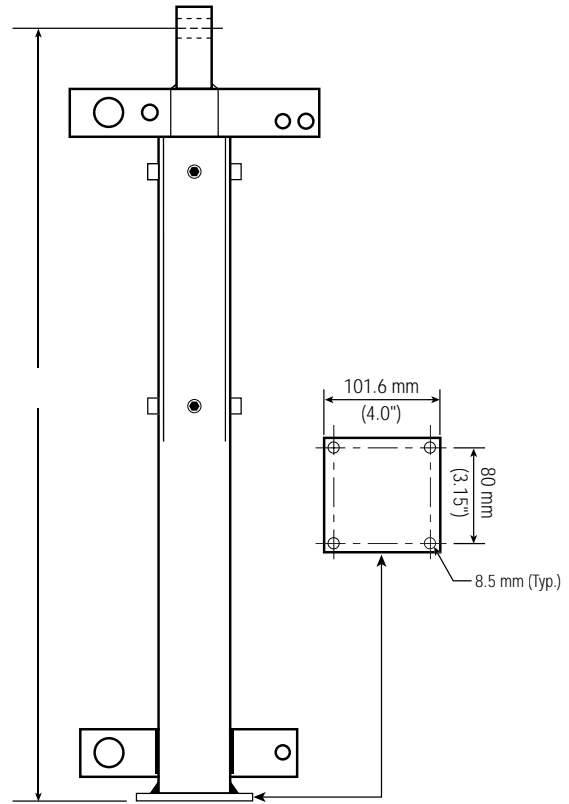

Torque Tubes

Part no.	Vertical travel		"B" extended		"B" retracted	
	in.	mm	in.	mm	in.	mm
EZTT150300	12	300	38.5	978	26.5	673
EZTT150600	24	600	62.5	1588	38.5	978
EZTT150900	36	900	86.5	2197	50.5	1283

Torque Tubes

Part no.	Weight of lower portion		Total weight	
	lbs	kg	lbs	kg
EZTT150300	9.8	4.43	20.9	9.5
EZTT150600	14.6	6.6	28.2	12.8
EZTT150900	19.2	8.77	30.5	16.1

Torque Tube Component Specifications



Extension tube features:

- Tubes are rugged stainless steel construction
- Welded construction

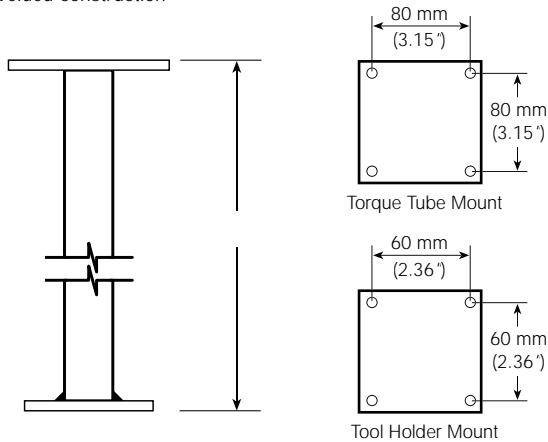

Extension Tubes					
Part no.	"C" dimension		Weight		
	in.	mm	lbs	kg	
ET150	6	150	2.6	1.2	
ET300	12	300	3.4	1.8	
ET450	18	450	5.1	2.3	
ET600	24	600	6.3	2.9	
ET750	30	750	7.5	3.4	
ET900	33	900	8.7	3.9	

Air cylinder features:

- Low friction cylinders
- High flow regulator
- Air cylinder includes cylinder, rear clevis and rod end clevis

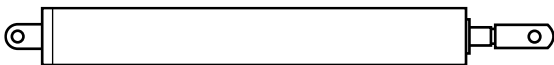

Air Cylinder ¹					
Part no.	Vertical travel		Weight		
	in.	mm	lbs	kg	
63001	11.8	300	5.00	2.27	
66001	23.6	600	6.96	3.16	
69001	35.4	900	11.00	4.99	

Note:
(1) Air filters come standard with regulators.

Cylinder Air Supply	
Part no.	Description
90050	Cylinder air supply package

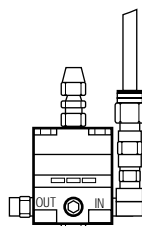

Tool holder features:

- Fixed tool holder.
- Accepts tools of 13 to 63 mm (.50 to 2.5 inch) diameter.
- Tool holder easily changes from horizontal to vertical
- 360 degree tool holder has generous 66.8 mm (2.63 inch) opening so that the tool head does not have to be removed for quick changes.
- 360° holder has a bronze bushing for easy rotation and long life.
- 360 degree tool holder can spin freely or can be locked every 45° when the index plunger is engaged.

Tool Holders					
Part no.	Description	"D" dimension		Weight	
		in.	mm	lbs	kg
52000	Fixed (2 axis) horiz./vertical	4.82	122	2.30	.90
52100	360 degree (3 axis) swivel	5.38	136.7	5.00	2.27

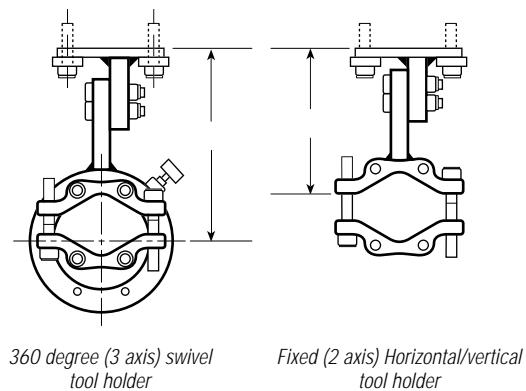

Note:
If a tool holder is ordered,
an extension tube must be ordered

IRAX spring balancers:

To determine model of balancer, add weights of lower portion of torque tube, extension tube, tool holder and tool.

IRAX Spring Balancer					
Part no.	Capacity		Weight		
	lbs	kg	lbs	kg	
BMDL-6	8.8 – 13.2	4 – 6	7.1	3.2	
BMDL-8	13.2 – 17.6	6 – 8	7.7	3.5	
BMDL-10	17.6 – 22.0	8 – 10	8.2	3.7	
BIDS-15	22 – 33	10 – 15	16.5	7.5	
BIDS-20	33 – 44	15 – 20	17.0	7.7	
BIDS-25	44 – 55	20 – 25	17.2	7.8	

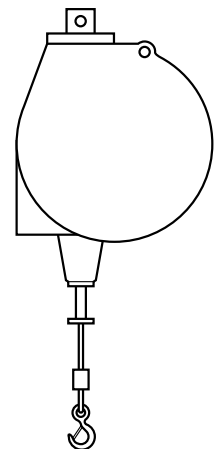

Heavy Duty Tool Arm

Heavy duty tool arm features:

- Lightweight, anodized aluminum construction.
- Modular metric design.
- 150 nm (110 ft/lb) of torque reaction.
- 50 kg/110 lb of capacity at 2 m/6.5 ft with 7 bar/100 psi.
- 500 mm/20 inches of vertical travel.
- Externally mounted sealed and lubricated roller bearings.
- Pneumatics control system consists of a single precision pneumatic regulator to allow balance at the end of the arm.
- Numerous mounting configurations.

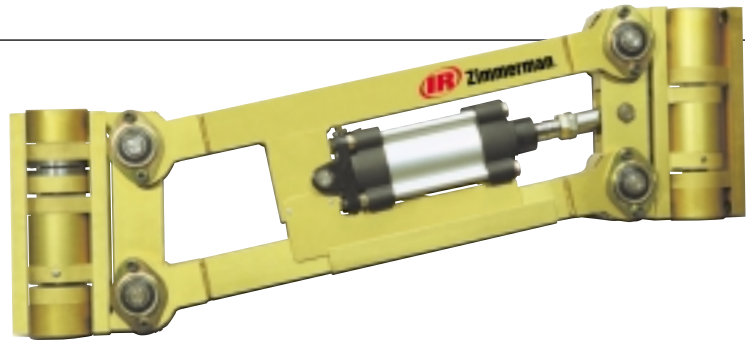

Options:

- Multiple tool holders and extension tubes (see torque tube component specifications for tool holders and extension tubes available).
- Optional pivot provides up to 220 degrees of rotation and includes adjustable stops to limit rotation.
- Optional locking pivot brake renders arm rigid to absorb torque.

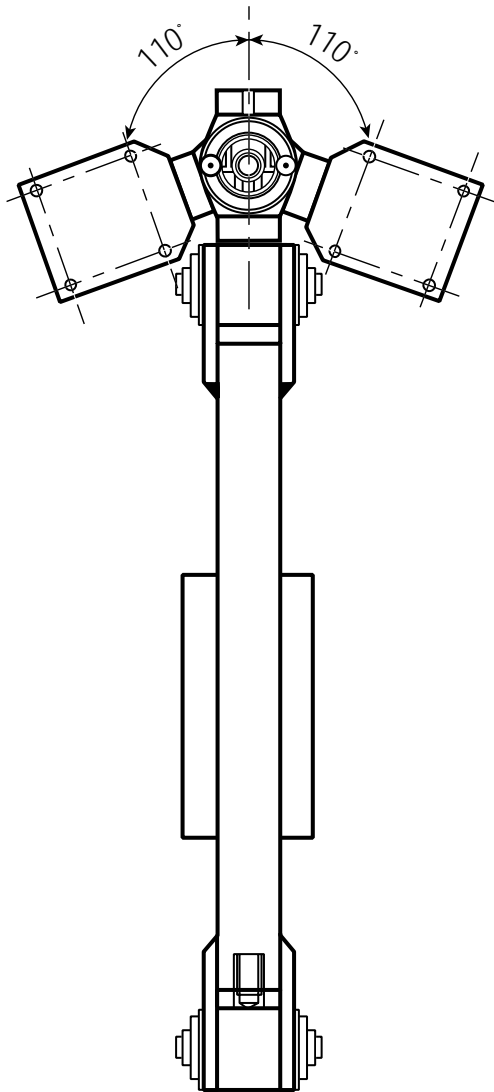

Top view of medium duty tool arm showing 220 degree rotation

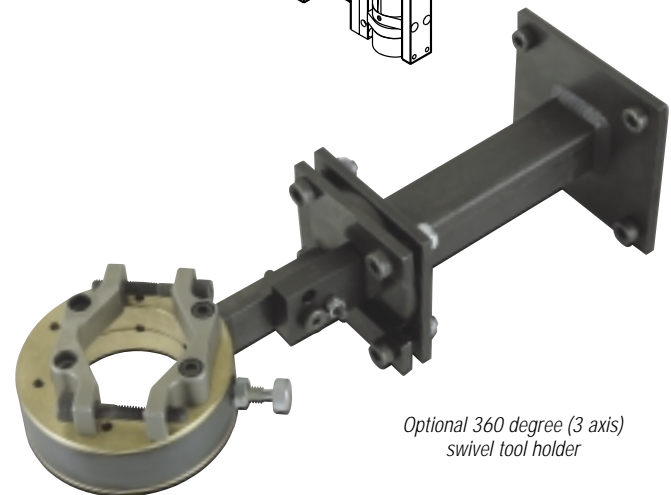
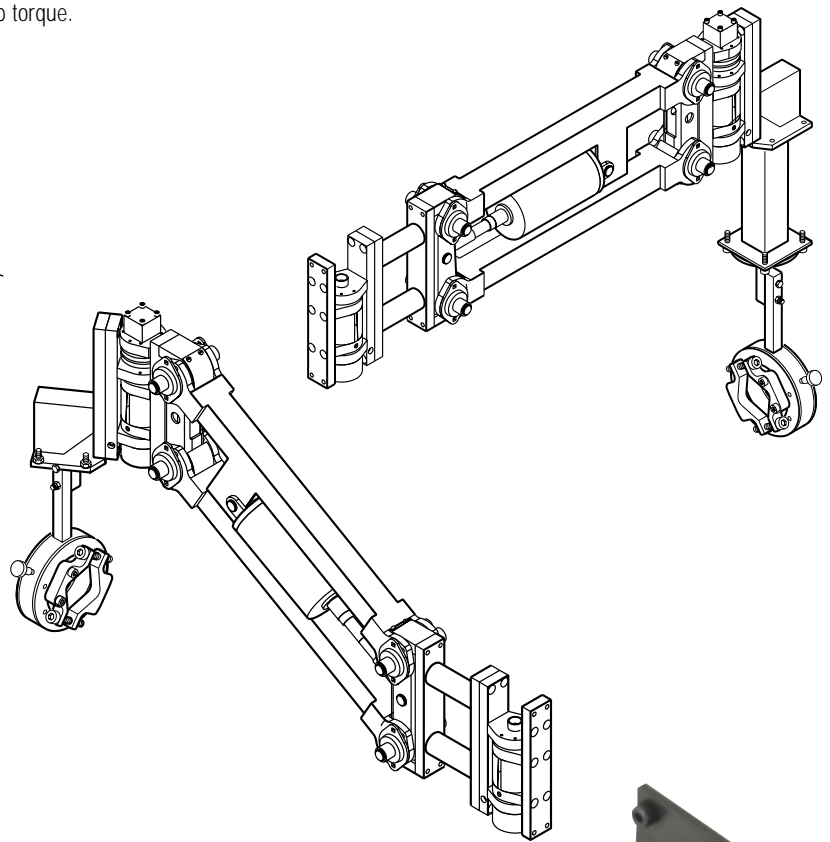

Optional 360 degree (3 axis) swivel tool holder

Heavy Duty Tool Arm Specifications

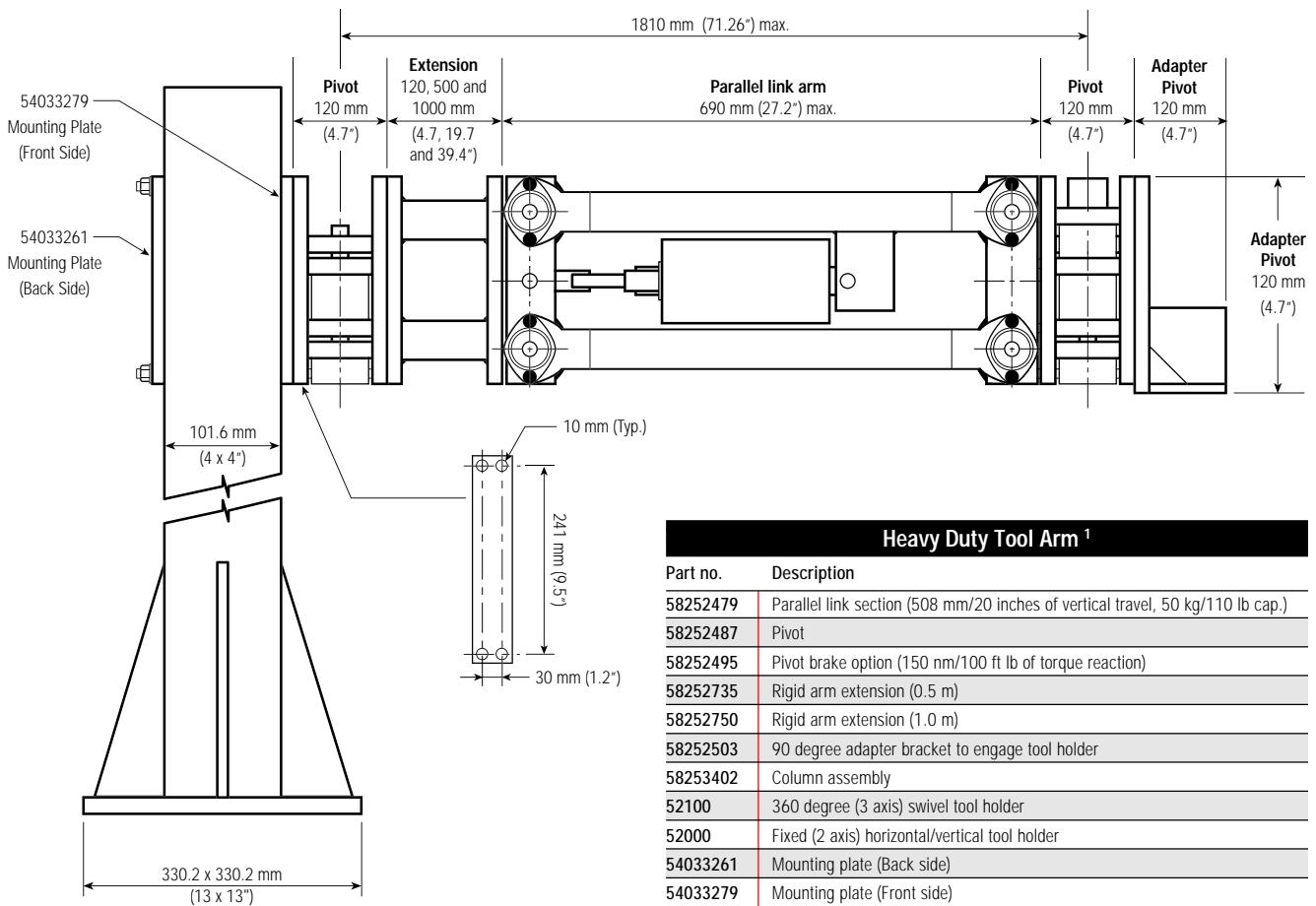
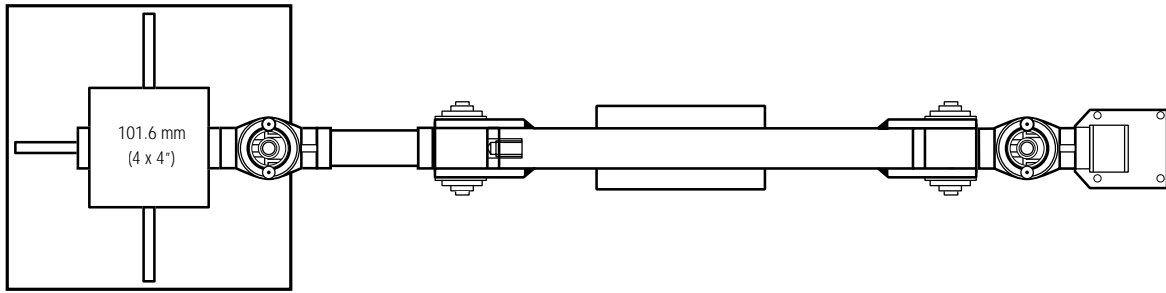

Heavy Duty Tool Arm ¹	
Part no.	Description
58252479	Parallel link section (508 mm/20 inches of vertical travel, 50 kg/110 lb cap.)
58252487	Pivot
58252495	Pivot brake option (150 nm/100 ft lb of torque reaction)
58252735	Rigid arm extension (0.5 m)
58252750	Rigid arm extension (1.0 m)
58252503	90 degree adapter bracket to engage tool holder
58253402	Column assembly
52100	360 degree (3 axis) swivel tool holder
52000	Fixed (2 axis) horizontal/vertical tool holder
54033261	Mounting plate (Back side)
54033279	Mounting plate (Front side)
54036009	Column

Note:
Standard column is 10 ft high. Please specify cut down lengths while ordering, if different height is desired.

Control packages, pivot brake option and cylinder control packages available on request.

Max weight capacity is 100 lbs (45.36 kg)

Max torque reaction is 150 Nm (110 ft lbs)

Note:
(1) Call Customer Service for control options.

IRAX Spring Balancers



Mechanical Spring Balancer

The IRAX red balancers from Ingersoll-Rand offer you five different series to fill all your spring balancing requirements. The light, medium, intermediate, heavy and super duty series cover weight balancing requirements from 1 lb. to 330 lbs (150 kg).

These mechanical balancers are ruggedly made of die cast aluminum. A safety locking device on the medium, heavy and super duty models is designed to prevent dropping of the tool should the spring fail. Easy to use controls allow for accurate spring adjustment.

With over 50 models to choose from, lifts ranging from 5 to 9 feet (1.5 to 2.7 m), IRAX balancers fill your spring balancer requirements with quality from Ingersoll-Rand.

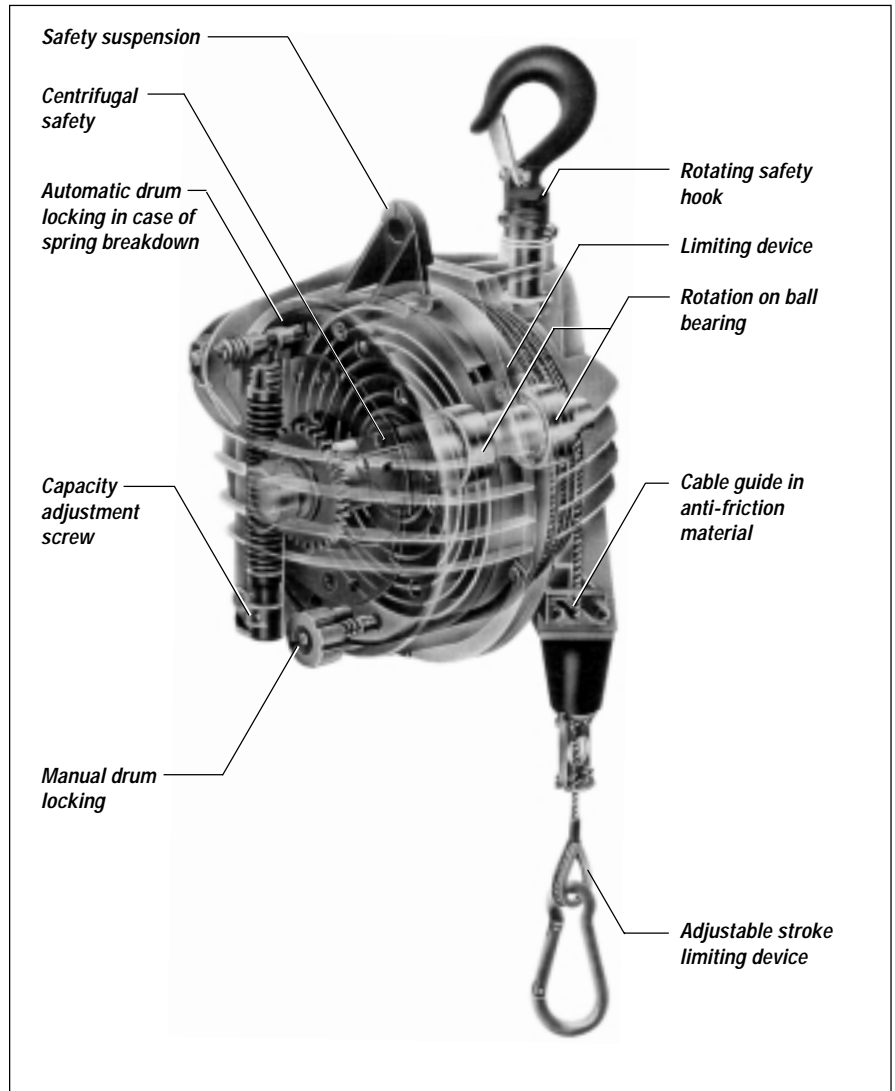

How to order Irax Balancers

Irax Model Driver					
<i>B</i>	<i>M</i>	<i>B</i>	<i>L</i>	<i>L</i>	<i>10</i>
<i>Balancer</i>	H = Heavy I = Intermediate L = Light <i>M</i> = Medium S = Super	<i>Duty</i>	<i>L</i> = Long cable (8.2'/2.5 m or 9.85'/3 m) <i>S</i> = Short cable (6.5'/2 m)	<i>L</i> = Locking type (pull to set/pull again to release)	<i>10</i> = Upper weight capacity in kilograms

IRAX Spring Balancers

0.9 to 6.6 lb (0.4 to 3 kg) Capacity



Light Duty - Capacity 0.9 to 6.6 lbs (0.4 to 3 kg)

- Rotary hook.
- Adjustable capacity and stroke limiting device.
- Self lubricating bushings.
- Auxiliary safety suspension.

IRAX

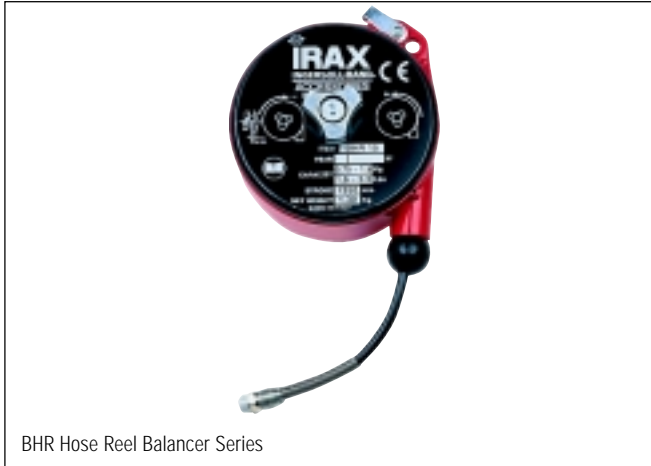

BHR Hose Reel Balancer Series



BLD Series

Hose Reel Balancer Specifications						
Model no.	Hose nipples	Capacity		Lift		
		lb	kg	ft	mm	
BHR-8	1/4"	7/8 - 1 3/4	.4 - .8	4 1/4	1300	
BHR-15	1/4"	1 1/2 - 3 1/3	.7 - 1.5	4 1/4	1300	
BHR-25	1/4"	2 5/8 - 5 1/2	1.2 - 2.5	4 1/4	1300	

Light Duty Specifications						
Model no.	Capacity		Weight		Lift	
	lb	kg	lb	kg	ft	mm
BLD-1	.9 - 2.2	0.4 - 1	1.3	0.6	5.2	1600
BLD-2	2.2 - 4.4	1 - 2	1.3	0.6	5.2	1600
BLD-3	4.4 - 6.6	2 - 3	1.3	0.7	5.2	1600

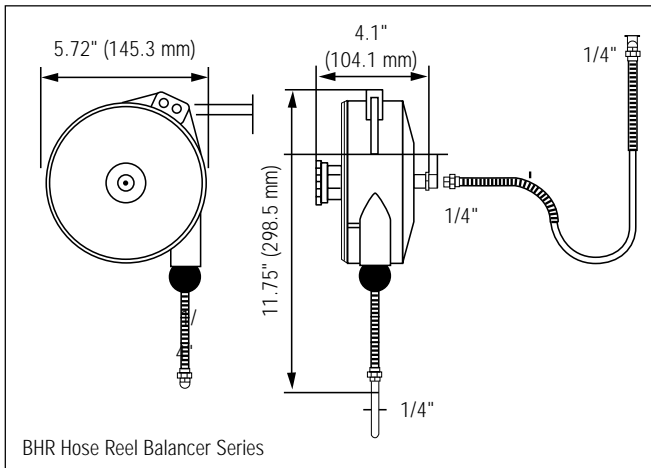

BHR Hose Reel Balancer Series

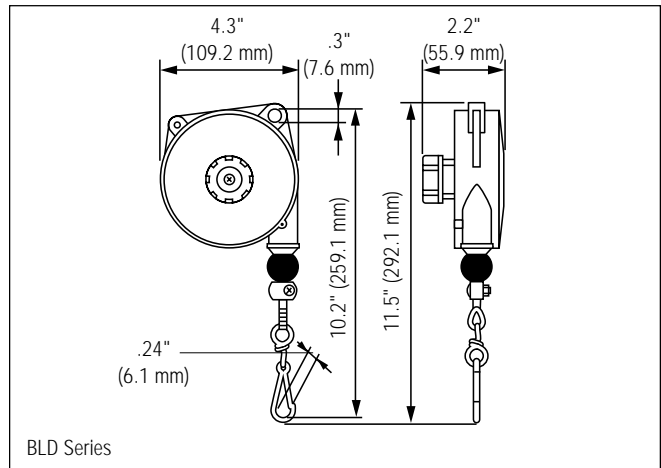

BLD Series

IRAX Spring Balancers

2.2 to 26.5 lb (1 to 12 kg) Capacity



Medium Duty - Capacity 2.2 to 26.5 lbs (1 to 12 kg)

- Safety device prevents dropping of load due to spring breakage (except BMDS-2).
- Anti-friction cable guide.
- Adjustable stroke limiting device

Medium Duty - Capacity 4.4 to 26.5 lbs (2 to 12 kg)

- Safety device prevents dropping of load due to spring breakage
- Anti-friction cable guide.
- Adjustable stroke limiting device



BMDS Series



BMDL Series

Medium Duty Specifications

Model no.	Capacity		Weight		Lift	
	lb	kg	lb	kg	ft	mm
BMDS-2	2.2 – 5.5	1 – 2.5	4.4	2.0	6.5	2000
BMDS-4	4.4 – 8.8	2 – 4	4.4	2.0	6.5	2000
BMDS-6	8.8 – 13.2	4 – 6	5.1	2.3	6.5	2000
BMDS-8	13.2 – 17.6	6 – 8	5.5	2.5	6.5	2000

Medium Duty long Lift Specifications

Model no.	Capacity		Weight		Lift	
	lb	kg	lb	kg	ft	mm
BMDL-4	4.4 – 8.8	2 – 4	6.4	2.9	8.2	2500
BMDL-6	8.8 – 13.2	4 – 6	7.1	3.2	8.2	2500
BMDL-8	13.2 – 17.6	6 – 8	7.7	3.5	8.2	2500
BMDL-10	17.6 – 22.0	8 – 10	8.2	3.7	8.2	2500
BMDL-12	22.0 – 26.5	10 – 12	8.8	4.0	8.2	2500

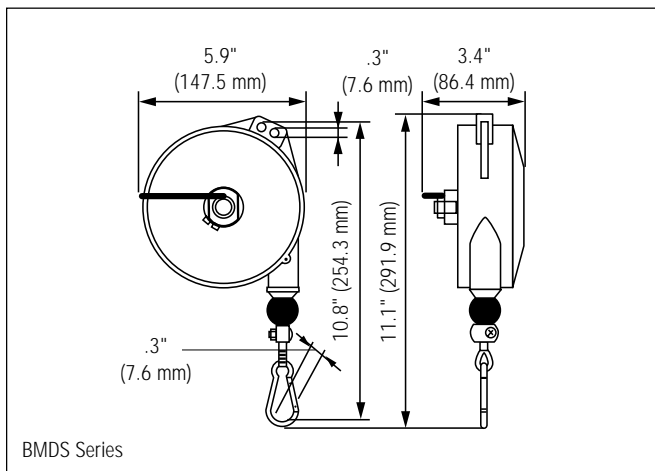

BMDS Series

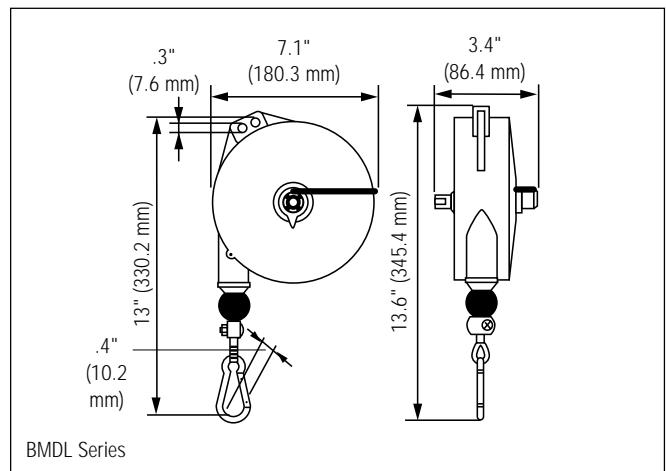

BMDL Series

IRAX

IRAX Spring Balancers

4.4 to 55 lb (2 to 25 kg) Capacity



IRAX

Locking type balancer with long lift

- Pull to set—pull again to release



BMDLL Series

Intermediate Duty - 22 to 55 lbs (10 to 25 kg)

- Safety device prevents load dropping due to spring breakage.
- Adjustable stroke limiting device
- Upper rotary suspension
- Safety hook
- Anti-friction cable guide
- Auxiliary safety suspension
- Auxiliary safety suspension



BIDS Series

Locking Type with Long Lift Specifications

Model no.	Capacity		Weight		Lift	
	lb	kg	lb	kg	ft	mm
BMDLL-4	4.4 – 8.8	2 – 4	6.6	3.0	8.2	2500
BMDLL-6	8.8 – 13.2	4 – 6	7.3	3.3	8.2	2500
BMDLL-8	13.2 – 17.6	6 – 8	7.9	3.6	8.2	2500
BMDLL-10	17.6 – 22.0	8 – 10	8.4	3.8	8.2	2500

Intermediate Duty Specifications

Model no.	Capacity		Weight		Lift	
	lb	kg	lb	kg	ft	mm
BIDS-15	22 – 33	10 – 15	16.5	7.5	6.5	2000
BIDS-20	33 – 44	15 – 20	17.0	7.7	6.5	2000
BIDS-25	44 – 55	20 – 25	17.2	7.8	6.5	2000

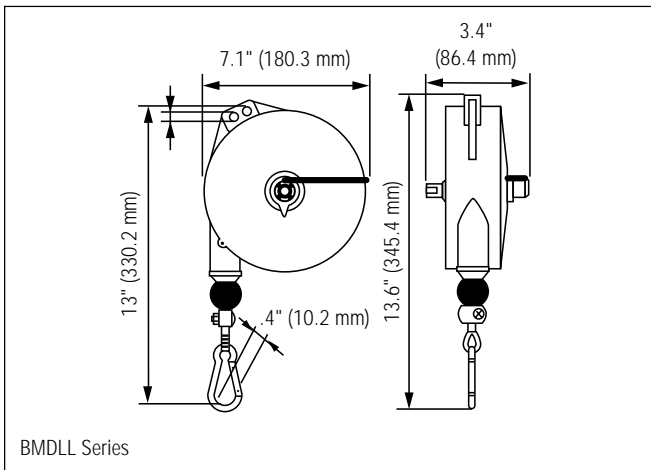

BMDLL Series

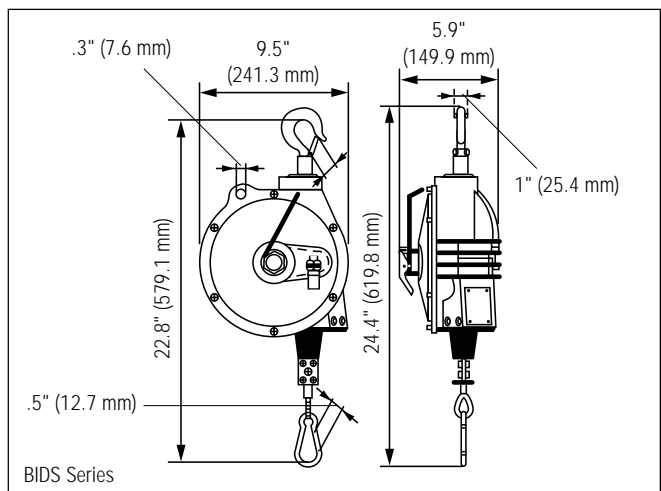

BIDS Series

IRAX Spring Balancers

22 to 143 lb (10 to 65 kg) Capacity



Heavy Duty - Capacity 22 to 143 lbs (10 to 65 kg)

- Safety device prevents load dropping due to spring breakage.
- Upper suspension with rotary safety hook.
- Precision guided cable winding prevents jamming.
- Anti-friction cable guide.
- Manual locking device for instant clamping or release.
- Worm screw capacity adjustment.
- Spring drum assembly.
- Optional floor controlled locking device available (BIL-7343).

Heavy Duty Specifications

Model no.	Capacity		Weight		Lift	
	lb	kg	lb	kg	ft	mm
BHD-15	22 – 33	10 – 15	22.7	10.3	6.5	2000
BHD-20	33 – 44	15 – 20	23.4	10.6	6.5	2000
BHD-25	44 – 55	20 – 25	24.7	11.2	6.5	2000
BHD-30	55 – 66	25 – 30	25.4	11.5	6.5	2000
BHD-35	66 – 77	30 – 35	26.0	11.8	6.5	2000
BHD-45	77 – 99	35 – 45	27.3	12.4	6.5	2000
BHD-55	99 – 121	45 – 55	27.6	12.5	6.5	2000
BHD-65	121 – 143	55 – 65	30.0	13.6	6.5	2000

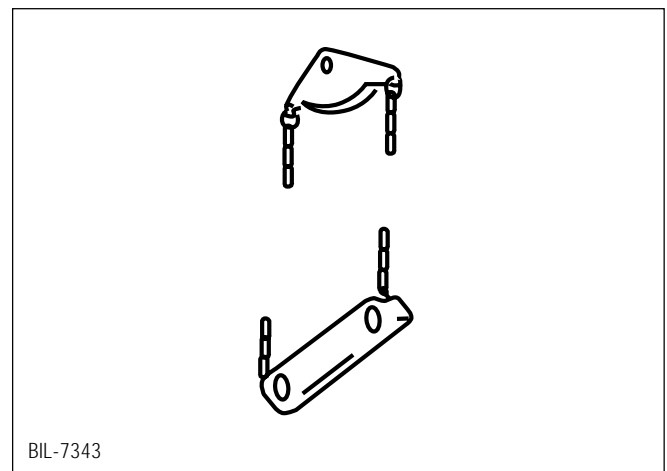
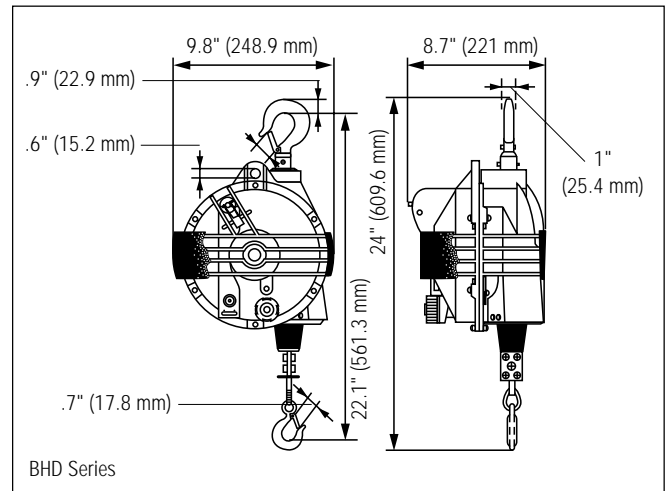

IRAX

IRAX Spring Balancers

33 to 132 lb (15 to 60 kg) Capacity



Super Duty - Capacity 33 to 363 lbs (15 to 165 kg)

- Safety device prevents load dropping due to spring breakage
- Manual locking device for instant clamping or release
- Anti-friction cable guide
- Cable replacement without balancer disassembly
- Optional floor controlled locking device available (BIL-7343)
- Precision guided cable winding prevents jamming
- Alignable rotating upper hook
- Worm screw capacity adjustment
- Cable visible for inspection
- Other sizes available on request

Super Duty Specifications						
Model no.	Capacity		Weight		Lift	
	lb	kg	lb	kg	ft	mm
BSD-20	33 – 44	15-20	41.9	19	8.2	2500
BSD-30	44 – 66	20-30	43.7	19.8	8.2	2500
BSD-40	66 – 88	30 – 40	45.9	20.8	8.2	2500
BSD-50	88 – 110	40 – 50	52.7	23.9	8.2	2500
BSD-60	110 – 132	50 – 60	56	25.4	8.2	2500
BSDL-20	33 – 44	15 – 20	42.1	19.1	9.85	3000
BSDL-35	44 – 55	20 – 25	43.9	19.9	9.85	3000
BSDL-35	55 – 77	25 – 35	46.1	20.9	9.85	3000

IRAX

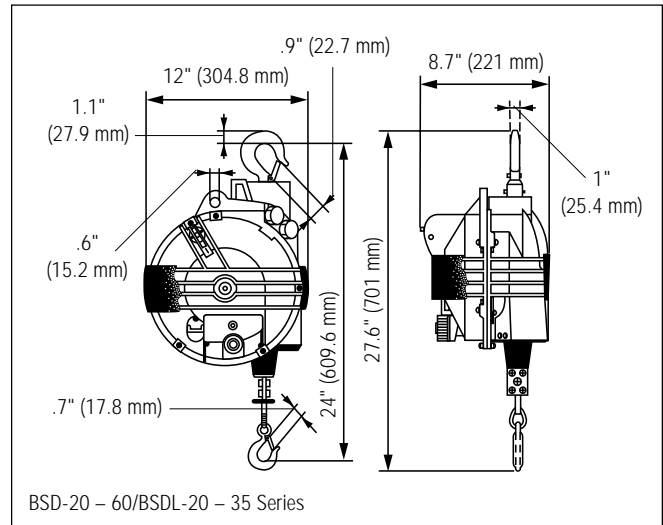
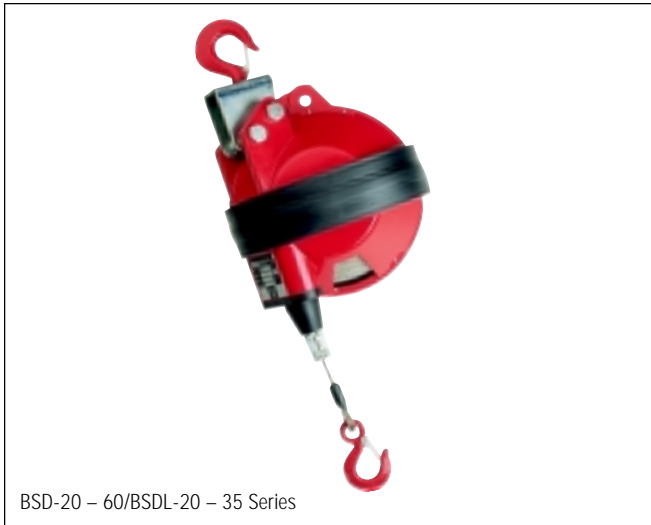

IRAX Spring Balancers

132 to 363 lb (60 to 165 kg) Capacity



IRAX



BSD-70 - 90/BSDL-45 - 90 Series



BSD-70 - 165/BSDL-100 - 150 Series

Super Duty Specifications

Model no.	Capacity		Weight		Lift	
	lb	kg	lb	kg	ft	mm
BSD-70	132 - 154	60 - 70	59.1	26.8	8.2	2500
BSD-80	154 - 176	70 - 80	61.3	27.8	8.2	2500
BSD-90	176 - 198	80 - 90	63.5	28.8	8.2	2500
BSDL-45	77 - 99	35 - 45	52.5	23.8	9.85	3000
BSDL-50	88 - 110	40 - 50	52.7	23.9	9.85	3000
BSDL-60	110 - 132	50 - 60	55.8	25.3	9.85	3000
BSDL-70	132 - 154	60 - 70	58.9	26.7	9.85	3000
BSDL-80	154 - 176	70 - 80	61.7	28.0	9.85	3000
BSDL-90	176 - 198	80 - 90	64.0	29.0	9.85	3000

Super Duty Specifications

Model no.	Capacity		Weight		Lift	
	lb	kg	lb	kg	ft	mm
BSD-70	132 - 154	60 - 70	59.1	26.8	8.2	2500
BSD-100	198 - 220	90 - 100	78.5	35.6	8.2	2500
BSD-120	220 - 265	100 - 120	85.3	38.7	8.2	2500
BSD-140	265 - 309	120 - 140	92.2	41.8	8.2	2500
BSD-150	287 - 330	130 - 150	98.1	44.5	8.2	2500
BSD-165	330 - 363	150 - 165	106.3	48.2	8.2	2500
BSDL-100	198 - 220	90 - 100	81.1	36.8	9.85	3000
BSDL-115	220 - 254	110 - 115	85.3	38.7	9.85	3000
BSDL-130	254 - 286	115 - 130	88.0	39.9	9.85	3000
BSDL-140	286 - 309	130 - 140	94.4	42.8	9.85	3000
BSDL-150	309 - 330	140 - 150	100.6	45.6	9.85	3000

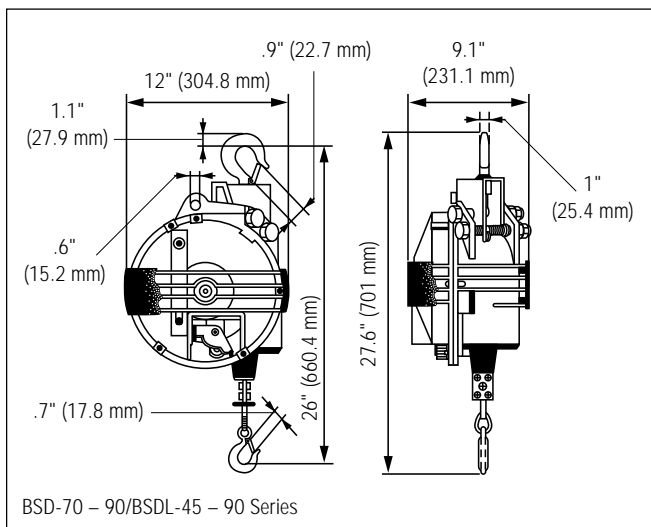

BSD-70 - 90/BSDL-45 - 90 Series

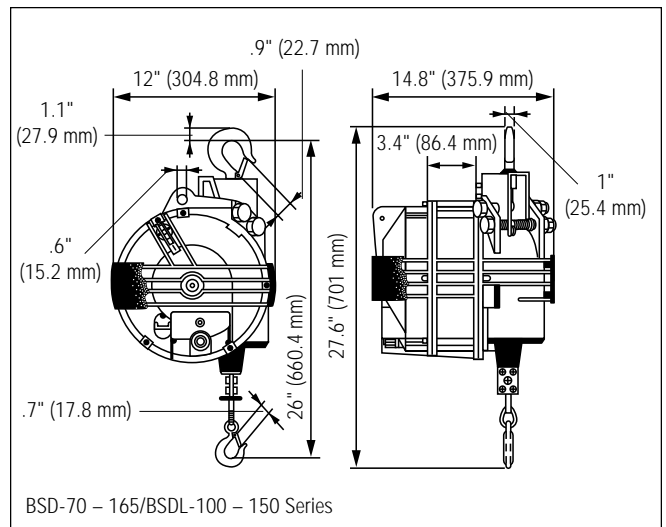

BSD-70 - 165/BSDL-100 - 150 Series

Quantum Series Electric Chain Hoist



1/8 – 5 metric ton Lifting Capacity

Features:

1. Eyebolt suspension:

An eyebolt suspension is standard with motorized and plain trolleys. Unlike rigid suspensions, the eyebolt suspension allows the hoist to pivot and align itself to the direction of load pull, reducing stress and wear. (Hook suspension can be substituted).



2. Overload clutch for asset protection:

The overload clutch is factory set to limit Quantum from lifting loads in excess of 150% of rated hoisting capacity.



3. Gear case:

Smooth and compact design with a helical/spur gear combination providing “grab free” movement and quiet, reliable operation. Optimum lubrication – Gears are lubricated with a semiliquid grease instead of oil, which is less likely to leak, eliminates oil level checks and clings to the gears even after long idle periods. Quantum will even work upside down.

4. Chain guide and wheel:

A “floating” chain guide precisely feeds chain onto a machined-matched five-pocket chain wheel. This system insures smooth, jam resistant operation, and extends load chain, and chain wheel life.



5. Optimized load chain:

Quantum load chain is precision formed from alloy steel, case hardened and zinc plated. The plating is an IR proprietary process, which resists corrosion better than any standard plating offered for load chain. Controlled elongation: Quantum chain is engineered to elongate a minimum of 10%. This ability to stretch reduces the possibility of catastrophic failure under sudden loading.



6. Motors:

High starting torque – Quantum motors are a totally enclosed non-ventilated (TENV) squirrel cage design. The H4 duty classification of the three phase models allows for 300 starts and 30 minutes “on time” per hour. Class F insulation allows a total thermal rating of 145° C at a 1.0 service factor, instead of the more common Class B insulation of 120° C. Quantum motors can take the heat!
Phased to your needs – Single phase motors are available as 115 or 230 volt. Because single-phase motors are subject to low voltages that create higher motor temperatures, these Quantum hoists are equipped with “klixons,” bimetal heat switches that prevent motor burnout. *Three phase motors* – are available in 230, 380, 460, and 575 volts, single and dual speeds. The 230/460 volt, single speed motors are field reconnectable.
Dual speed motors – feature 4, 5, or 6 to 1 high to low speed ratios instead of the typical 3 to 1 ratios. The advantages are unsurpassed load control, reduced cycle time and improved productivity. The overload clutch and Class F insulation eliminate the cost of “klixons.”

7. Brake:

Metal discs stack up against wear – Quantum has a state-of-the-art AC motor brake employing all-steel discs. Multiple stacking significantly increases braking surface area, reducing wear and extending life. This system eliminates the breakage common with fiber discs and the heavier steel springs and DC solenoids they require. Quantum brake discs are guaranteed for the life of the hoist.



8. Electrical controls:

Safety-first pendent – Quantum’s safety-first pendent control handles are comfortable and fit securely in the operator’s hand. Each low voltage (42 volt) control handle integrates a large, red emergency stop button. Operating buttons are clearly marked with high contrast arrows, feature soft push action, and are horizontally aligned for easier operation.
Emergency shut-off – Activated from the pendent handle, the mainline contactor disconnects the power to the hoist and trolley motor providing “shut-off protection” in an emergency situation.
Easy accessibility – Quantum enclosures are weatherproof, NEMA 3R rated. The removal of just four fasteners (slot-head on the electrical parts cover and allen-head on the mechanical parts cover) allows access to components. Since electrical and mechanical components can be accessed separately, service is quick and clean.

9. Limit switches:

Fail-safe limits – Quantum limit levers are recessed in the hoist enclosure. This clean, obstruction-free assembly virtually eliminates accidental activation of switches. Upper and lower switches are activated by the hook and end stop, eliminating time-consuming adjustments.



Quantum Series Electric Chain Hoist

1/8 – 5 metric ton Lifting Capacity



Design Features:

- UL and C-UL listed (except 380 volt units). Complete unit listed number is 5D48.
- Meets I-R's interpretation of ANSI B30.16 and pertinent European FEM standards.
- Small compact light weight, high tensile strength, die cast aluminum housing.
- NEMA 3R hoist enclosure and NEMA 4X pendent enclosure can be used outdoors.
- Universal tread trolley wheels fit tapered or flat flange beams.
- Hook, eyebolt, push trolley or motorized trolley suspensions.
- Safety lugs on all trolleys.
- Anti-tip lugs on motorized trolleys.
- Well balanced, modular design.

Options:

- Trolley brake.
- Chain container.
- External strain relief.
- Power cord lengths.
- Geared limits.
- Handy Handle.
- 110 Volt controls.
- Inertia type mechanical load brake.
- Pendent with vertical aligned buttons.
- Pendent with additional 2 or 4 aligned buttons.
- Bullard top and bottom hooks.

Optional pendent handle with additional buttons



Optional geared limit switch



- Inertia type mechanical load brake. This option specifies a bolt-on inertia mechanical load brake. The inertia type brake responds to overspeed of the load. It's similar in function to many safety devices including elevator safety brakes and automotive seat belts. If a dual brake is required this option is ideal as it does not reduce duty cycle, from heat created by drag, or require adjustment to compensate for wear.

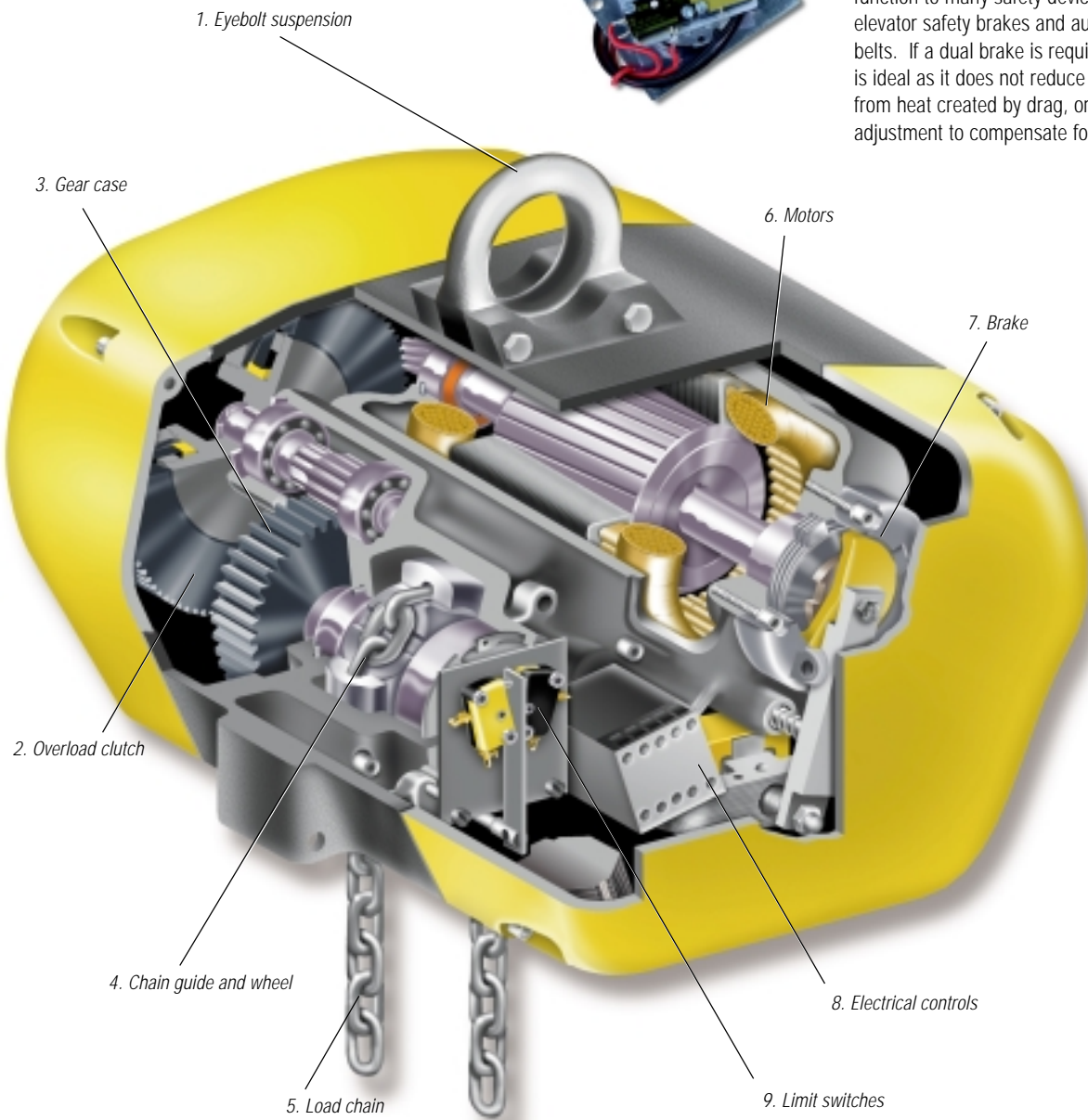

Quantum Series Electric Chain Hoist



1/8 – 5 metric ton Lifting Capacity

Quantum Series specifications

Base model	Cap. metric tons	Chain falls	Lift spd fpm	Motor hp used	Amperage						Chain & pendent wt (lbs/ft)	Eye & hook wt (lbs)	Curve radius min	S beam min	Push trolley, PT Series		Wt ⁽¹⁾ lbs
					Single phase 115V	230V	230V	Three phase 460V	575V	380V					Flange Width (in.) A	D	
Single Phase (Single Speed)																	
Q50-1NS12	1/8	1	32	0.3	13	6.7	n/a	n/a	n/a	n/a	.24	49	36	4	2 ¹¹ / ₁₆ – 4 ¹¹ / ₁₆	2 ¹¹ / ₁₆ – 8 ¹ / ₁₆	69
Q50-2NS25	1/4	2	16	0.3	13	6.7	n/a	n/a	n/a	n/a	.48	56	36	4	2 ¹¹ / ₁₆ – 4 ¹¹ / ₁₆	2 ¹¹ / ₁₆ – 8 ¹ / ₁₆	76
Q50-1NS25	1/4	1	36	0.7	13	6.7	n/a	n/a	n/a	n/a	.37	54	36	4	2 ¹¹ / ₁₆ – 4 ¹¹ / ₁₆	2 ¹¹ / ₁₆ – 8 ¹ / ₁₆	74
Q50-1NS50	1/2	1	18	0.7	13	6.7	n/a	n/a	n/a	n/a	.37	54	36	4	2 ¹¹ / ₁₆ – 4 ¹¹ / ₁₆	2 ¹¹ / ₁₆ – 8 ¹ / ₁₆	74
Q100-1NS50	1/2	1	32	1.2	16	8.0	n/a	n/a	n/a	n/a	.70	104	36	4	2 ¹¹ / ₁₆ – 4 ¹¹ / ₁₆	2 ¹¹ / ₁₆ – 8 ¹ / ₁₆	124
Q50-2NS100	1	2	9	0.7	13	6.7	n/a	n/a	n/a	n/a	.74	60	36	5	3 – 5 ¹ / ₄	3 – 8 ¹ / ₁₆	80
Q100-2NS100	1	2	16	1.2	16	8.0	n/a	n/a	n/a	n/a	1.40	123	36	5	3 – 5 ¹ / ₄	3 – 8 ¹ / ₁₆	178
Q200-1NS100	1	1	16	1.2	13	7.6	n/a	n/a	n/a	n/a	1.18	139	36	5	3 – 5 ¹ / ₄	3 – 8 ¹ / ₁₆	211
Q200-2NS200	2	2	8	1.2	13	7.6	n/a	n/a	n/a	n/a	2.36	167	48	6	3 ¹¹ / ₃₂ – 6	3 ¹¹ / ₃₂ – 8 ¹ / ₁₆	222
Q500-1NS200	2	1	12	1.8	n/a	10.0	n/a	n/a	n/a	n/a	1.52	157	48	6	3 ¹¹ / ₃₂ – 6	3 ¹¹ / ₃₂ – 8 ¹ / ₁₆	212
Q500-2NS300	3	2	6.2	1.4	n/a	10.0	n/a	n/a	n/a	n/a	3.04	173	60	8	4 – 6 ¹ / ₄	4 – 8 ¹ / ₁₆	279
Q500-2NS400	4	2	6.2	1.9	n/a	10.0	n/a	n/a	n/a	n/a	3.04	173	60	10	4 ²¹ / ₃₂ – 7 ¹ / ₄	4 ²¹ / ₃₂ – 8 ¹ / ₁₆	279
Three Phase (Single Speed)																	
Q50-1NS12	1/8	1	32	0.3	n/a	n/a	2.4	1.2	1.0	1.2	.24	49	36	4	2 ¹¹ / ₁₆ – 4 ¹¹ / ₁₆	2 ¹¹ / ₁₆ – 8 ¹ / ₁₆	69
Q50-1NS25	1/4	1	32	0.6	n/a	n/a	2.4	1.2	1.0	1.2	.24	49	36	4	2 ¹¹ / ₁₆ – 4 ¹¹ / ₁₆	2 ¹¹ / ₁₆ – 8 ¹ / ₁₆	69
Q50-1HS25	1/4	1	64	1.2	n/a	n/a	4.2	2.1	1.7	2.1	.37	54	36	4	2 ¹¹ / ₁₆ – 4 ¹¹ / ₁₆	2 ¹¹ / ₁₆ – 8 ¹ / ₁₆	74
Q50-1NS50	1/2	1	36	1.4	n/a	n/a	3.8	1.9	1.6	1.6	.37	54	36	4	2 ¹¹ / ₁₆ – 4 ¹¹ / ₁₆	2 ¹¹ / ₁₆ – 8 ¹ / ₁₆	74
Q100-1HS50	1/2	1	64	2.4	n/a	n/a	11.0	5.7	4.6	5.0	.70	100	36	4	2 ¹¹ / ₁₆ – 4 ¹¹ / ₁₆	2 ¹¹ / ₁₆ – 8 ¹ / ₁₆	120
Q50-2NS100	1	2	18	1.4	n/a	n/a	3.8	1.9	1.6	1.9	.74	60	36	5	3 – 5 ¹ / ₄	3 – 8 ¹ / ₁₆	90
Q100-1NS100	1	1	32	2.4	n/a	n/a	7.6	3.8	3.1	3.3	.70	100	36	5	3 – 5 ¹ / ₄	3 – 8 ¹ / ₁₆	130
Q100-2NS200	2	2	16	2.4	n/a	n/a	7.6	3.8	3.1	3.3	1.40	116	48	6	3 ¹¹ / ₃₂ – 6	3 ¹¹ / ₃₂ – 8 ¹ / ₁₆	171
Q300-1NS200	2	1	32	4.8	n/a	n/a	16.0	7.8	6.3	6.8	1.18	149	48	6	3 ¹¹ / ₃₂ – 6	3 ¹¹ / ₃₂ – 8 ¹ / ₁₆	204
Q200-2NS300	3	2	16	3.6	n/a	n/a	12.0	6.0	4.8	6.0	2.36	161	60	8	4 – 6 ¹ / ₄	4 – 8 ¹ / ₁₆	236
Q300-2NS400	4	2	16	4.8	n/a	n/a	16.0	7.8	6.3	6.8	3.04	173	60	10	4 ²¹ / ₃₂ – 7 ¹ / ₄	4 ²¹ / ₃₂ – 8 ¹ / ₁₆	279
Q500-2NS500	5	2	12.5	4.7	n/a	n/a	17.0	8.4	6.8	7.1	3.04	173	60	10	4 ²¹ / ₃₂ – 7 ¹ / ₄	4 ²¹ / ₃₂ – 8 ¹ / ₁₆	279
Three Phase (Dual Speed)																	
Q50-1ND12	1/8	1	32/6	0.3	n/a	n/a	3.6	1.8	1.5	1.8	.24	51	36	4	2 ¹¹ / ₁₆ – 4 ¹¹ / ₁₆	2 ¹¹ / ₁₆ – 8 ¹ / ₁₆	71
Q50-1ND25	1/4	1	32/6	0.6	n/a	n/a	3.6	1.8	1.5	1.6	.24	51	36	4	2 ¹¹ / ₁₆ – 4 ¹¹ / ₁₆	2 ¹¹ / ₁₆ – 8 ¹ / ₁₆	76
Q50-1HD25	1/4	1	50/8	1.2	n/a	n/a	4.4	2.2	1.8	2.2	.37	56	36	4	2 ¹¹ / ₁₆ – 4 ¹¹ / ₁₆	2 ¹¹ / ₁₆ – 8 ¹ / ₁₆	78
Q50-1ND50	1/2	1	36/6	1.4	n/a	n/a	4.4	2.2	1.8	2.1	.37	56	36	4	2 ¹¹ / ₁₆ – 4 ¹¹ / ₁₆	2 ¹¹ / ₁₆ – 8 ¹ / ₁₆	76
Q100-1HD50	1/2	1	64/16	2.4	n/a	n/a	9.8	4.9	4.0	4.9	.70	108	36	4	2 ¹¹ / ₁₆ – 4 ¹¹ / ₁₆	2 ¹¹ / ₁₆ – 8 ¹ / ₁₆	128
Q50-2ND100	1	2	18/3	1.4	n/a	n/a	4.4	2.2	1.8	2.1	.74	62	36	5	3 – 5 ¹ / ₄	3 – 8 ¹ / ₁₆	92
Q100-1ND100	1	1	32/8	2.4	n/a	n/a	8.0	4.0	3.2	3.5	.70	108	36	5	3 – 5 ¹ / ₄	3 – 8 ¹ / ₁₆	138
Q100-2ND200	2	2	16/4	2.4	n/a	n/a	8.0	4.0	3.2	3.5	1.40	125	48	6	3 ¹¹ / ₃₂ – 6	3 ¹¹ / ₃₂ – 8 ¹ / ₁₆	180
Q300-1ND200	2	1	32/8	4.8	n/a	n/a	16.0	7.8	6.3	6.8	1.18	156	48	6	3 ¹¹ / ₃₂ – 6	3 ¹¹ / ₃₂ – 8 ¹ / ₁₆	211
Q200-2ND300	3	2	16/3	3.6	n/a	n/a	12.0	6.0	4.8	6.0	2.36	165	60	8	4 – 6 ¹ / ₄	4 – 8 ¹ / ₁₆	240
Q300-2ND400	4	2	16/4	4.8	n/a	n/a	16.0	7.8	6.3	6.8	3.04	178	60	10	4 ²¹ / ₃₂ – 7 ¹ / ₄	4 ²¹ / ₃₂ – 8 ¹ / ₁₆	284
Q500-2ND500	5	2	12.5/3	4.7	n/a	n/a	17.0	8.4	6.8	7.1	3.04	178	60	10	4 ²¹ / ₃₂ – 7 ¹ / ₄	4 ²¹ / ₃₂ – 8 ¹ / ₁₆	284

Notes:

Multiply speeds shown by .83 for 380V / 50 Hz units

(1) 10 foot lift capacity only.



Eyebolt and Hook suspension



Motorized Trolley Suspension



PT Series Plain Trolley with Hook Suspension

Quantum Series Electric Chain Hoist



1/8 – 5 metric ton Lifting Capacity

Quantum Series Motorized Trolley Specifications – M1, M3 and M4

Base Model	Capacity metric tons	Lifting speed fpm			Motor hp	3 Phase Amperage				S beam hght min in.	Min curve radius in.	Flange width (in.)				Wt ⁽¹⁾ lbs
		M1	M2	M4		230V	460V	575V	380V			A	B	C	D	
Three Phase (Single Speed)																
Q50-1NS12	1/8	39	39	63	.03	1.5	0.75	0.85	0.6	4	48	1 ³¹ / ₃₂ - 3 ⁷ / ₈	3 ¹⁵ / ₁₆ - 5 ⁷ / ₈	5 ²⁹ / ₃₂ - 7 ²⁷ / ₃₂	7 ⁷ / ₈ - 9 ⁷ / ₁₆	109
Q50-1NS25	1/4	39	39	63	.03	1.5	0.75	0.85	0.6	4	48	1 ³¹ / ₃₂ - 3 ⁷ / ₈	3 ¹⁵ / ₁₆ - 5 ⁷ / ₈	5 ²⁹ / ₃₂ - 7 ²⁷ / ₃₂	7 ⁷ / ₈ - 9 ⁷ / ₁₆	109
Q50-1HS25	1/4	39	39	63	.03	1.5	0.75	0.85	0.6	4	48	1 ³¹ / ₃₂ - 3 ⁷ / ₈	3 ¹⁵ / ₁₆ - 5 ⁷ / ₈	5 ²⁹ / ₃₂ - 7 ²⁷ / ₃₂	7 ⁷ / ₈ - 9 ⁷ / ₁₆	114
Q50-1NS50	1/2	39	39	63	.03	1.5	0.75	0.85	0.6	4	48	1 ³¹ / ₃₂ - 3 ⁷ / ₈	3 ¹⁵ / ₁₆ - 5 ⁷ / ₈	5 ²⁹ / ₃₂ - 7 ²⁷ / ₃₂	7 ⁷ / ₈ - 9 ⁷ / ₁₆	114
Q100-1HS50	1/2	39	39	63	.03	1.5	0.75	0.85	0.6	4	48	3 - 5 ¹⁵ / ₃₂	5 ¹ / ₂ - 7 ⁵³ / ₆₄	7 ⁷ / ₈ - 10 ³ / ₁₆	10 ¹ / ₂ - 12 ⁵ / ₈	174
Q50-2NS100	1	39	39	63	.03	1.5	0.75	0.85	0.6	4	48	1 ³¹ / ₃₂ - 3 ⁷ / ₈	3 ¹⁵ / ₁₆ - 5 ⁷ / ₈	5 ²⁹ / ₃₂ - 7 ²⁷ / ₃₂	7 ⁷ / ₈ - 9 ⁷ / ₁₆	120
Q100-1NS100	1	39	39	63	.03	1.5	0.75	0.85	0.6	6	60	3 - 5 ¹⁵ / ₃₂	5 ¹ / ₂ - 7 ⁵³ / ₆₄	7 ⁷ / ₈ - 10 ³ / ₁₆	10 ¹ / ₂ - 12 ⁵ / ₈	174
Q100-2NS200	2	39	39	63	.03	1.5	0.75	0.85	0.6	6	60	3 - 5 ¹⁵ / ₃₂	5 ¹ / ₂ - 7 ⁵³ / ₆₄	7 ⁷ / ₈ - 10 ³ / ₁₆	10 ¹ / ₂ - 12 ⁵ / ₈	190
Q300-1NS200	2	39	39	63	.03	1.5	0.75	0.85	0.6	10	72	2 ³ / ₁₆ - 4 ¹¹ / ₁₆	4 ²³ / ₃₂ - 7 ¹ / ₁₆	7 ³ / ₃₂ - 9 ¹³ / ₃₂	9 ⁷ / ₁₆ - 11 ¹³ / ₁₆	263
Q200-2NS300	3	39	39	63	.03	1.5	0.75	0.85	0.6	10	72	2 ³ / ₁₆ - 4 ¹¹ / ₁₆	4 ²³ / ₃₂ - 7 ¹ / ₁₆	7 ³ / ₃₂ - 9 ¹³ / ₃₂	9 ⁷ / ₁₆ - 11 ¹³ / ₁₆	281
Q300-2NS400	4	39	39	63	.03	1.5	0.75	0.85	0.6	10	72	2 ³ / ₁₆ - 4 ¹¹ / ₁₆	4 ²³ / ₃₂ - 7 ¹ / ₁₆	7 ³ / ₃₂ - 9 ¹³ / ₃₂	9 ⁷ / ₁₆ - 11 ¹³ / ₁₆	287
Q500-2NS500	5	39	39	63	.04	3.0	1.5	1.7	1.2	10	72	2 ³ / ₁₆ - 4 ¹¹ / ₁₆	4 ²³ / ₃₂ - 7 ¹ / ₁₆	7 ³ / ₃₂ - 9 ¹³ / ₃₂	9 ⁷ / ₁₆ - 11 ¹³ / ₁₆	287
Three Phase (Dual Speed)																
Q50-1ND12	1/8	39	39/13	63/21	.03	1.5	0.75	0.85	0.6	4	48	1 ³¹ / ₃₂ - 3 ⁷ / ₈	3 ¹⁵ / ₁₆ - 5 ⁷ / ₈	5 ²⁹ / ₃₂ - 7 ²⁷ / ₃₂	7 ⁷ / ₈ - 9 ⁷ / ₁₆	114
Q50-1ND25	1/4	39	39/13	63/21	.03	1.5	0.75	0.85	0.6	4	48	1 ³¹ / ₃₂ - 3 ⁷ / ₈	3 ¹⁵ / ₁₆ - 5 ⁷ / ₈	5 ²⁹ / ₃₂ - 7 ²⁷ / ₃₂	7 ⁷ / ₈ - 9 ⁷ / ₁₆	111
Q50-1HD25	1/4	39	39/13	63/21	.03	1.5	0.75	0.85	0.6	4	48	1 ³¹ / ₃₂ - 3 ⁷ / ₈	3 ¹⁵ / ₁₆ - 5 ⁷ / ₈	5 ²⁹ / ₃₂ - 7 ²⁷ / ₃₂	7 ⁷ / ₈ - 9 ⁷ / ₁₆	116
Q50-1ND50	1/2	39	39/13	63/21	.03	1.5	0.75	0.85	0.6	4	48	1 ³¹ / ₃₂ - 3 ⁷ / ₈	3 ¹⁵ / ₁₆ - 5 ⁷ / ₈	5 ²⁹ / ₃₂ - 7 ²⁷ / ₃₂	7 ⁷ / ₈ - 9 ⁷ / ₁₆	116
Q100-1HD50	1/2	39	39/13	63/21	.03	1.5	0.75	0.85	0.6	4	48	3 - 5 ¹⁵ / ₃₂	5 ¹ / ₂ - 7 ⁵³ / ₆₄	7 ⁷ / ₈ - 10 ³ / ₁₆	10 ¹ / ₂ - 12 ⁵ / ₈	182
Q50-2ND100	1	39	39/13	63/21	.04	1.5	0.75	0.85	0.6	4	48	1 ³¹ / ₃₂ - 3 ⁷ / ₈	3 ¹⁵ / ₁₆ - 5 ⁷ / ₈	5 ²⁹ / ₃₂ - 7 ²⁷ / ₃₂	7 ⁷ / ₈ - 9 ⁷ / ₁₆	122
Q100-1ND100	1	39	39/13	63/21	.04	1.5	0.75	0.85	0.6	6	60	3 - 5 ¹⁵ / ₃₂	5 ¹ / ₂ - 7 ⁵³ / ₆₄	7 ⁷ / ₈ - 10 ³ / ₁₆	10 ¹ / ₂ - 12 ⁵ / ₈	182
Q100-2ND200	2	39	39/13	63/21	.04	1.5	0.75	0.85	0.6	6	60	3 - 5 ¹⁵ / ₃₂	5 ¹ / ₂ - 7 ⁵³ / ₆₄	7 ⁷ / ₈ - 10 ³ / ₁₆	10 ¹ / ₂ - 12 ⁵ / ₈	199
Q300-1ND200	2	39	39/13	63/21	.04	1.5	0.75	0.85	0.6	10	72	2 ³ / ₁₆ - 4 ¹¹ / ₁₆	4 ²³ / ₃₂ - 7 ¹ / ₁₆	7 ³ / ₃₂ - 9 ¹³ / ₃₂	9 ⁷ / ₁₆ - 11 ¹³ / ₁₆	270
Q200-2ND300	3	39	39/13	63/21	.04	1.5	0.75	0.85	0.6	10	72	2 ³ / ₁₆ - 4 ¹¹ / ₁₆	4 ²³ / ₃₂ - 7 ¹ / ₁₆	7 ³ / ₃₂ - 9 ¹³ / ₃₂	9 ⁷ / ₁₆ - 11 ¹³ / ₁₆	285
Q300-2ND400	4	39	39/13	63/21	.04	1.5	0.75	0.85	0.6	10	72	2 ³ / ₁₆ - 4 ¹¹ / ₁₆	4 ²³ / ₃₂ - 7 ¹ / ₁₆	7 ³ / ₃₂ - 9 ¹³ / ₃₂	9 ⁷ / ₁₆ - 11 ¹³ / ₁₆	292
Q500-2ND500	5	39	39/13	63/21	.04	3.0	1.5	1.7	1.2	10	72	2 ³ / ₁₆ - 4 ¹¹ / ₁₆	4 ²³ / ₃₂ - 7 ¹ / ₁₆	7 ³ / ₃₂ - 9 ¹³ / ₃₂	9 ⁷ / ₁₆ - 11 ¹³ / ₁₆	292

Notes:

Multiply speeds shown by .83 for 380V / 50 Hz units
 (1) 10 foot lift capacity only.

Quantum Series Handy Handle

Pendent Control

NEW Handy Handle Control:

Ergonomically designed to provide control and operation at the hook as a robotic power extension of the operator's arm. The load can be positioned and controlled with one hand, freeing the other hand to position the load.

The Handy Handle can be ordered separately as a kit, to convert any 1/8, 1/4 and 1/2 ton single line Quantum hoist, or as an "H" control option on a new hoist. Each Handy Handle is standard with single or dual speed thumb control lever switches and includes the Quantum red stop safety button. A socket connection at the bottom allows the standard hook to be easily replaced by custom end effectors or grabs.



Quantum Series Electric Chain Hoist

1/8 – 5 metric ton Lifting Capacity



Quantum Series Dimensions (in.)

Base model	Capacity metric tons	Eye bolt AE	Hook mount AH	Push trolley AP	Motor trolley AM	B	C	D	E	F	G	H	I	J	K
Single Phase (Single Speed)															
Q50-1NS12	1/8	15 ⁵ / ₈	17 ¹ / ₂	18 ¹ / ₈	n/a	29 ²⁹ / ₃₂	1 ¹ / ₈	1 ¹ / ₈	1 ⁵ / ₈	5 ⁵ / ₈	10 ²⁹ / ₃₂	7 ³ / ₁₆	6 ¹ / ₈	5 ⁵ / ₈	2 ¹ / ₈
Q50-2NS25	1/4	15 ¹³ / ₃₂	17 ⁵ / ₁₆	17 ²⁹ / ₃₂	n/a	29 ²⁹ / ₃₂	1 ¹ / ₈	1 ¹ / ₈	1 ⁵ / ₈	5 ⁵ / ₈	10 ²⁹ / ₃₂	7 ³ / ₁₆	6 ¹ / ₈	6 ¹³ / ₃₂	2 ¹ / ₈
Q50-1NS25	1/4	16 ³ / ₁₆	18 ¹³ / ₃₂	18 ³ / ₄	n/a	1	1 ¹ / ₈	1 ¹ / ₈	1 ⁵ / ₈	5 ⁵ / ₈	10 ²⁹ / ₃₂	7 ³ / ₁₆	6 ¹ / ₈	5 ³ / ₄	2 ¹ / ₈
Q50-1NS50	1/2	16 ³ / ₁₆	18 ¹³ / ₃₂	18 ³ / ₄	n/a	1	1 ¹ / ₈	1 ¹ / ₈	1 ⁵ / ₈	5 ⁵ / ₈	10 ²⁹ / ₃₂	7 ³ / ₁₆	6 ¹ / ₈	5 ³ / ₄	2 ¹ / ₈
Q100-1NS50	1/2	19 ¹ / ₈	21 ¹ / ₂	21 ⁵ / ₈	n/a	1 ³ / ₁₆	1 ³ / ₈	1 ³ / ₁₆	2	5 ⁵ / ₈	12 ¹³ / ₃₂	9 ¹ / ₈	7 ⁵ / ₁₆	8 ¹ / ₈	3
Q50-2NS100	1	16 ³ / ₁₆	18 ¹³ / ₃₂	18 ³ / ₄	n/a	1	1 ¹ / ₈	1 ¹ / ₈	1 ⁵ / ₈	5 ⁵ / ₈	10 ²⁹ / ₃₂	7 ³ / ₁₆	6 ¹ / ₈	6 ³ / ₄	2 ¹ / ₈
Q100-2NS100	1	22	24 ¹ / ₂	24 ¹ / ₂	n/a	1 ³ / ₁₆	1 ³ / ₈	1 ³ / ₁₆	2	1 ¹³ / ₁₆	12 ¹³ / ₃₂	9 ¹ / ₈	7 ⁵ / ₁₆	9 ¹ / ₂	3
Q200-1NS100	1	21 ¹³ / ₁₆	22 ³ / ₁₆	24 ⁵ / ₁₆	n/a	1 ¹ / ₂	1 ¹ / ₂	1 ⁵ / ₈	3	1 ¹ / ₂	15 ¹ / ₈	9 ¹³ / ₃₂	8 ¹³ / ₁₆	9 ¹³ / ₁₆	5 ¹³ / ₃₂
Q200-2NS200	2	26 ¹ / ₂	26 ²⁹ / ₃₂	28 ²⁹ / ₃₂	n/a	1 ¹ / ₂	1 ¹ / ₂	1 ⁵ / ₈	3	1 ¹ / ₂	15 ¹ / ₈	9 ¹³ / ₃₂	8 ¹³ / ₁₆	11 ¹ / ₂	5 ¹³ / ₃₂
Q500-1NS200	2	21 ²⁹ / ₃₂	22 ⁵ / ₁₆	24 ¹³ / ₃₂	n/a	1 ¹ / ₂	1 ¹ / ₂	1 ⁵ / ₈	3	1 ¹ / ₂	15 ¹ / ₈	9 ¹³ / ₃₂	8 ¹³ / ₁₆	9 ²⁹ / ₃₂	5 ¹³ / ₃₂
Q500-2NS300	3	26 ³ / ₄	27 ¹ / ₈	29 ⁵ / ₁₆	n/a	1 ¹ / ₂	1 ¹ / ₂	1 ⁵ / ₈	3	1 ¹ / ₂	15 ¹ / ₈	9 ¹³ / ₃₂	8 ¹³ / ₁₆	11 ¹ / ₂	5 ¹³ / ₃₂
Q500-2NS400	4	26 ³ / ₄	27 ¹ / ₈	29 ⁵ / ₁₆	n/a	1 ¹ / ₂	1 ¹ / ₂	1 ⁵ / ₈	3	1 ¹ / ₂	15 ¹ / ₈	9 ¹³ / ₃₂	8 ¹³ / ₁₆	11 ¹ / ₂	5 ¹³ / ₃₂
Three phase (Single and Dual speed)															
Q50-1NS12	1/8	15 ⁵ / ₈	17 ¹ / ₂	18 ¹ / ₈	17 ¹ / ₂	29 ²⁹ / ₃₂	1 ¹ / ₈	1 ¹ / ₈	1 ⁵ / ₈	5 ⁵ / ₈	10 ²⁹ / ₃₂	7 ³ / ₁₆	6 ¹ / ₈	5 ⁵ / ₈	2 ¹ / ₈
Q50-1NS25	1/4	15 ⁵ / ₈	17 ¹ / ₂	18 ¹ / ₈	17 ¹ / ₂	29 ²⁹ / ₃₂	1 ¹ / ₈	1 ¹ / ₈	1 ⁵ / ₈	5 ⁵ / ₈	10 ²⁹ / ₃₂	7 ³ / ₁₆	6 ¹ / ₈	5 ⁵ / ₈	2 ¹ / ₈
Q50-1HS25	1/4	16 ³ / ₁₆	18 ¹³ / ₃₂	18 ³ / ₄	18 ¹ / ₈	1	1 ¹ / ₈	1 ¹ / ₈	1 ⁵ / ₈	5 ⁵ / ₈	10 ²⁹ / ₃₂	7 ³ / ₁₆	6 ¹ / ₈	5 ³ / ₄	2 ¹ / ₈
Q50-1NS50	1/2	16 ³ / ₁₆	18 ¹³ / ₃₂	18 ³ / ₄	18 ¹ / ₈	1	1 ¹ / ₈	1 ¹ / ₈	1 ⁵ / ₈	5 ⁵ / ₈	10 ²⁹ / ₃₂	7 ³ / ₁₆	6 ¹ / ₈	5 ³ / ₄	2 ¹ / ₈
Q100-1HS50	1/2	19 ¹ / ₈	21 ¹ / ₂	21 ⁵ / ₈	21 ¹³ / ₃₂	1 ³ / ₁₆	1 ³ / ₈	1 ³ / ₁₆	2	1 ¹³ / ₁₆	12 ¹³ / ₃₂	9 ¹ / ₈	7 ⁵ / ₁₆	8 ¹ / ₈	3
Q50-2NS100	1	16 ³ / ₁₆	18 ¹³ / ₃₂	18 ³ / ₄	18 ¹ / ₈	1	1 ¹ / ₈	1 ¹ / ₈	1 ⁵ / ₈	5 ⁵ / ₈	10 ²⁹ / ₃₂	7 ³ / ₁₆	6 ¹ / ₈	6 ³ / ₄	2 ¹ / ₈
Q100-1NS100	1	19 ¹ / ₈	21 ¹ / ₂	21 ⁵ / ₈	21 ¹³ / ₃₂	1 ³ / ₁₆	1 ³ / ₈	1 ³ / ₁₆	2	1 ¹³ / ₁₆	12 ¹³ / ₃₂	9 ¹ / ₈	7 ⁵ / ₁₆	8 ¹ / ₈	3
Q100-2NS100	2	22	26 ¹ / ₈	24 ¹ / ₂	24 ¹³ / ₃₂	1 ³ / ₁₆	1 ³ / ₈	1 ³ / ₁₆	2	1 ¹³ / ₁₆	12 ¹³ / ₃₂	9 ¹ / ₈	8 ¹³ / ₁₆	9 ¹ / ₂	3
Q300-1NS200	2	21 ²⁹ / ₃₂	22 ⁵ / ₁₆	24 ¹³ / ₃₂	24 ¹ / ₈	1 ¹ / ₂	1 ¹ / ₂	1 ⁵ / ₈	3	1 ¹ / ₂	15 ¹ / ₈	9 ¹³ / ₃₂	8 ¹³ / ₁₆	9 ²⁹ / ₃₂	5 ¹³ / ₃₂
Q200-2NS300	3	26 ¹ / ₂	26 ²⁹ / ₃₂	29 ¹ / ₈	28 ⁵ / ₈	1 ¹ / ₂	1 ¹ / ₂	1 ⁵ / ₈	3	1 ¹ / ₂	15 ¹ / ₈	9 ¹³ / ₃₂	8 ¹³ / ₁₆	11 ¹ / ₂	5 ¹³ / ₃₂
Q300-2NS400	4	26 ¹ / ₂	26 ²⁹ / ₃₂	29	28 ⁵ / ₈	1 ¹ / ₂	1 ¹ / ₂	1 ⁵ / ₈	3	1 ¹ / ₂	15 ¹ / ₈	9 ¹³ / ₃₂	8 ¹³ / ₁₆	11 ¹ / ₂	5 ¹³ / ₃₂
Q500-2NS500	5	26 ³ / ₄	27 ¹ / ₈	29 ⁵ / ₁₆	28 ²⁹ / ₃₂	1 ¹ / ₂	1 ¹ / ₂	1 ⁵ / ₈	3	1 ¹ / ₂	15 ¹ / ₈	9 ¹³ / ₃₂	8 ¹³ / ₁₆	11 ¹ / ₂	5 ¹³ / ₃₂

Quantum

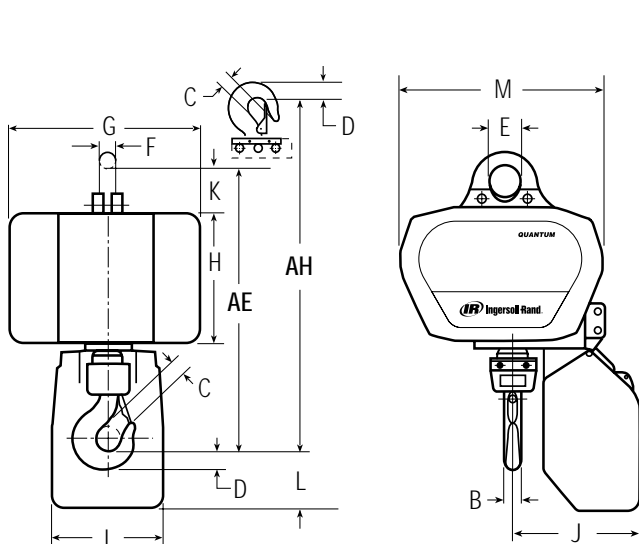

Eyebolt and Hook suspension

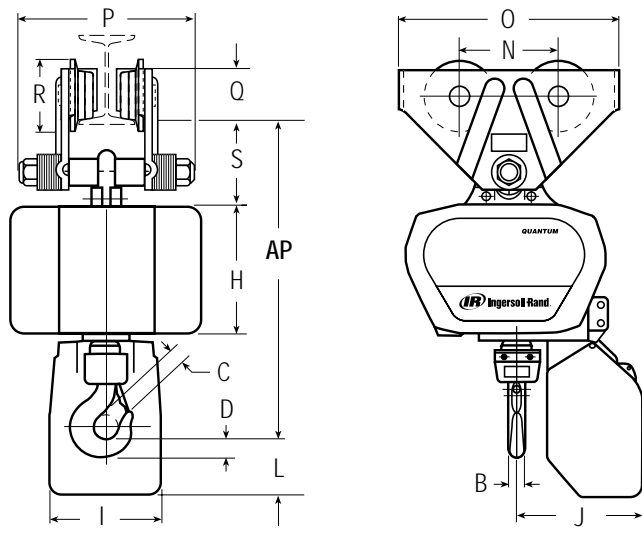

PT Series Plain Trolley with Hook Suspension

Quantum Series Electric Chain Hoist

1/8 – 5 metric ton Lifting Capacity



Quantum Series Dimensions (in.)

Base model	Cap. metric tons	L ¹	M	N	O	P	Q	R	S	T	U	V	W	X	Y	Z
Single Phase (Single Speed)																
Q50-1NS12	1/8	6 ¹⁵ / ₁₆	10	4 ¹ / ₂	10	8 ¹⁵ / ₁₆	2 ³ / ₁₆	3 ⁷ / ₁₆	4 ⁵ / ₈	n/a	n/a	n/a	n/a	n/a	n/a	n/a
Q50-2NS25	1/4	6 ¹⁵ / ₁₆	10	4 ¹ / ₂	10	8 ¹⁵ / ₁₆	2 ³ / ₁₆	3 ⁷ / ₁₆	4 ⁵ / ₈	n/a	n/a	n/a	n/a	n/a	n/a	n/a
Q50-1NS25	1/4	6 ¹⁵ / ₁₆	10	4 ¹ / ₂	10	8 ¹⁵ / ₁₆	2 ³ / ₁₆	3 ⁷ / ₁₆	4 ⁵ / ₈	n/a	n/a	n/a	n/a	n/a	n/a	n/a
Q50-1NS50	1/2	6 ¹⁵ / ₁₆	10	4 ¹ / ₂	10	8 ¹⁵ / ₁₆	2 ³ / ₁₆	3 ⁷ / ₁₆	4 ⁵ / ₈	n/a	n/a	n/a	n/a	n/a	n/a	n/a
Q100-1NS50	1/2	11 ¹ / ₂	12 ³ / ₄	4 ¹ / ₂	10	8 ¹⁵ / ₁₆	2 ³ / ₁₆	3 ⁷ / ₁₆	5 ¹ / ₂	n/a	n/a	n/a	n/a	n/a	n/a	n/a
Q50-2NS100	1	6 ¹⁵ / ₁₆	10	5 ⁵ / ₈	12 ⁵ / ₈	10	2 ¹³ / ₁₆	4 ³ / ₁₆	4 ⁵ / ₈	n/a	n/a	n/a	n/a	n/a	n/a	n/a
Q100-2NS100	1	11 ¹ / ₂	12 ³ / ₄	5 ⁵ / ₈	12 ⁵ / ₈	10	2 ¹³ / ₁₆	4 ³ / ₁₆	5 ¹ / ₂	n/a	n/a	n/a	n/a	n/a	n/a	n/a
Q200-1NS100	1	12 ³ / ₄	13 ³ / ₁₆	5 ⁵ / ₈	12 ⁵ / ₈	10	2 ¹³ / ₁₆	4 ³ / ₁₆	7 ¹⁵ / ₁₆	n/a	n/a	n/a	n/a	n/a	n/a	n/a
Q200-2NS200	2	12 ³ / ₄	13 ³ / ₁₆	6 ¹ / ₂	14 ¹⁵ / ₁₆	11 ³ / ₁₆	4 ⁵ / ₁₆	5 ³ / ₄	7 ¹⁵ / ₁₆	n/a	n/a	n/a	n/a	n/a	n/a	n/a
Q500-1NS200	2	12 ³ / ₄	13 ³ / ₁₆	6 ¹ / ₂	14 ¹⁵ / ₁₆	11 ³ / ₁₆	4 ⁵ / ₁₆	5 ³ / ₄	7 ¹⁵ / ₁₆	n/a	n/a	n/a	n/a	n/a	n/a	n/a
Q500-2NS300	3	12 ³ / ₄	13 ³ / ₁₆	6 ¹ / ₂	14 ³ / ₁₆	12 ⁷ / ₁₆	4 ⁵ / ₁₆	5 ³ / ₄	8	n/a	n/a	n/a	n/a	n/a	n/a	n/a
Q500-2NS400	4	12 ³ / ₄	13 ³ / ₁₆	6 ³ / ₄	15 ⁷ / ₁₆	14 ¹⁵ / ₁₆	4 ⁷ / ₁₆	6 ³ / ₁₆	8	n/a	n/a	n/a	n/a	n/a	n/a	n/a
Three Phase (Single and Dual Speed)																
Q50-1ND12	1/8	6 ¹⁵ / ₁₆	10	4 ¹ / ₂	10	8 ¹⁵ / ₁₆	2 ³ / ₁₆	3 ⁷ / ₁₆	4 ⁵ / ₈	10 ¹ / ₂	8 ³ / ₁₆	2 ³ / ₄	3 ¹³ / ₁₆	4 ³ / ₁₆	8 ⁵ / ₈	2 ³ / ₁₆
Q50-1ND25	1/4	6 ¹⁵ / ₁₆	10	4 ¹ / ₂	10	8 ¹⁵ / ₁₆	2 ³ / ₁₆	3 ⁷ / ₁₆	4 ⁵ / ₈	10 ¹ / ₂	8 ³ / ₁₆	2 ³ / ₄	3 ¹³ / ₁₆	4 ³ / ₁₆	8 ⁵ / ₈	2 ³ / ₁₆
Q50-1HD25	1/4	6 ¹⁵ / ₁₆	10	4 ¹ / ₂	10	8 ¹⁵ / ₁₆	2 ³ / ₁₆	3 ⁷ / ₁₆	4 ⁵ / ₈	10 ¹ / ₂	8 ³ / ₁₆	2 ³ / ₄	3 ¹³ / ₁₆	4 ³ / ₁₆	8 ⁵ / ₈	2 ³ / ₁₆
Q50-1ND50	1/2	6 ¹⁵ / ₁₆	10	4 ¹ / ₂	10	8 ¹⁵ / ₁₆	2 ³ / ₁₆	3 ⁷ / ₁₆	4 ⁵ / ₈	1 ¹ / ₂	8 ³ / ₁₆	2 ³ / ₄	3 ¹³ / ₁₆	4 ³ / ₁₆	5 ⁵ / ₈	2 ³ / ₁₆
Q100-1HD50	1/2	11 ¹ / ₂	12 ³ / ₄	4 ¹ / ₂	10	8 ¹⁵ / ₁₆	2 ³ / ₁₆	3 ⁷ / ₁₆	5 ¹ / ₂	10 ⁵ / ₈	8 ⁵ / ₁₆	3 ³ / ₁₆	4 ³ / ₁₆	4 ¹³ / ₁₆	9 ¹³ / ₁₆	1 ¹ / ₂
Q50-2ND100	1	6 ¹⁵ / ₁₆	10	5 ⁵ / ₈	12 ⁵ / ₈	10	2 ¹³ / ₁₆	4 ³ / ₁₆	4 ⁵ / ₈	10 ¹ / ₂	8 ³ / ₁₆	2 ³ / ₄	3 ¹³ / ₁₆	4 ³ / ₁₆	8 ⁵ / ₈	2 ³ / ₁₆
Q100-1ND100	1	11 ¹ / ₂	12 ³ / ₄	5 ⁵ / ₈	12 ⁵ / ₈	10	2 ¹³ / ₁₆	4 ³ / ₁₆	5 ¹ / ₂	10 ⁵ / ₈	8 ⁵ / ₁₆	3 ³ / ₁₆	4 ³ / ₁₆	4 ¹³ / ₁₆	9 ¹³ / ₁₆	1 ¹ / ₂
Q100-2ND100	2	11 ¹ / ₂	12 ³ / ₄	6 ¹ / ₂	14 ¹⁵ / ₁₆	11 ³ / ₁₆	4 ⁵ / ₁₆	5 ³ / ₄	5 ¹ / ₂	10 ⁵ / ₈	8 ⁵ / ₁₆	3 ³ / ₁₆	4 ³ / ₁₆	4 ¹³ / ₁₆	9 ¹³ / ₁₆	1 ¹ / ₂
Q300-1ND200	2	12 ³ / ₄	13 ³ / ₁₆	6 ¹ / ₂	14 ¹⁵ / ₁₆	11 ³ / ₁₆	4 ⁵ / ₁₆	5 ³ / ₄	7 ¹⁵ / ₁₆	10 ¹³ / ₁₆	8 ⁷ / ₂	4	4 ³ / ₄	5 ²⁹ / ₃₂	12 ³ / ₁₆	5 ⁵ / ₁₆
Q200-2ND300	3	12 ³ / ₄	13 ³ / ₁₆	6 ¹ / ₂	14 ³ / ₁₆	14 ³ / ₁₆	4 ⁵ / ₁₆	5 ³ / ₄	8	10 ¹³ / ₁₆	8 ¹ / ₂	4	4 ³ / ₄	5 ²⁹ / ₃₂	12 ³ / ₁₆	5 ⁵ / ₁₆
Q300-2ND400	4	12 ³ / ₄	13 ³ / ₁₆	6 ³ / ₄	15 ⁷ / ₁₆	14 ¹⁵ / ₁₆	4 ⁷ / ₁₆	6 ³ / ₁₆	8	10 ¹³ / ₁₆	8 ¹ / ₂	4	4 ³ / ₄	5 ²⁹ / ₃₂	12 ³ / ₁₆	5 ⁵ / ₁₆
Q500-2ND500	5	12 ³ / ₄	13 ³ / ₁₆	6 ³ / ₄	15 ⁷ / ₁₆	14 ¹⁵ / ₁₆	4 ⁷ / ₁₆	6 ³ / ₁₆	8	10 ¹³ / ₁₆	9 ³ / ₄	4	4 ³ / ₄	5 ²⁹ / ₃₂	12 ³ / ₁₆	5 ⁵ / ₁₆

Notes:

- Multiply speeds shown by .83 for 380V / 50 Hz units.
- (1) 10 foot lift capacity only. Consult factory for additional lifts.

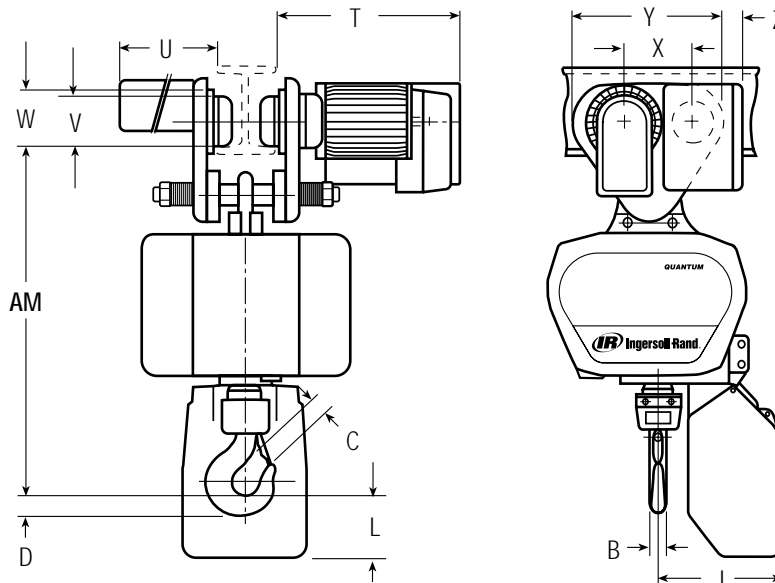

Motorized Trolley Suspension

I-Beam Specifications



The following table shows the standard size (H dimension), flange widths (W dimensions) and weights for both American Standard I-beams and Wide Flange H-beams. I-beams designated with an asterisk (*) denote New Series applications which conform to ASTM A6 standards, effective September 1, 1978.

Wide Flange						American Standard					
H in.	W in.	Weight per ft/lbs	H in.	W in.	Weight per ft/lbs	H in.	W in.	Weight per ft/lbs	H in.	W in.	Weight per ft/lbs
6	3.940	8.5	10	10.117	66.0	16*	6.985	36	4	2.663	7.7
6*	4.0	9.0	10*	10.130	68.0	16	7.0	40	4	2.796	9.5
6	4.0	12.0	10	10.170	72.0	16*	6.995	40	5	3.004	10.0
6*	4.0	12.0	10	10.190	77.0	16	7.039	45	5	3.284	14.75
6	4.030	16.0	10*	10.190	77.0	16*	7.035	45	6	3.332	12.5
6*	4.030	16.0	10*	10.625	88.0	16	7.073	50	6	3.565	17.25
6*	5.990	15.0	10	10.275	89.0	16*	7.070	50	7	3.662	15.3
6	5.995	15.5	10	10.340	100.0	16*	7.120	57	7	3.860	20.0
6	6.020	20.0	10*	10.340	100.0	16	8.464	58	8	4.001	18.4
6*	6.018	20.0	10	10.415	112.0	16*	10.235	67	8	4.171	23.0
6	6.080	25.0	10*	10.415	112.0	16*	10.295	77	10	4.661	25.4
6*	6.080	25.0	12	3.968	14.0	16*	10.365	89	10	4.944	35.0
8	3.940	10.0	12*	3.970	14.0	16*	10.425	100	12	5.0	31.8
8*	3.940	10.0	12*	3.990	16.0	16	11.502	88	12	5.078	35.0
8	4.0	13.0	12	4.0	16.5	16	11.5	96	12	5.252	40.8
8*	4.0	13.0	12	4.005	19.0	18	6.0	35	12	5.477	50.0
8	4.015	15.0	12*	4.007	19.0	18*	6.0	35	15	5.501	42.9
8*	4.015	15.0	12	4.030	22.0	18	6.015	40	15	5.640	50.0
8	5.250	17.0	12*	4.030	22.0	18*	6.015	40	18	6.001	54.7
8*	5.250	18.0	12*	6.490	26.0	18*	6.060	46	18	6.251	70.0
8	5.268	20.0	12	6.497	27.0	18	7.477	45	20	6.25	65.4
8*	5.270	21.0	12*	6.520	30.0	18	7.5	50	20	6.385	75.0
8	6.495	24.0	12	6.525	31.0	18*	7.5	50	20	7.060	86.0
8*	6.5	24.0	12*	6.560	35.0	18	7.532	55	20	7.200	96.0
8	6.535	28.0	12	6.565	36.0	18*	7.530	55	24	7.001	79.9
8*	6.535	28.0	12	8.0	40.0	18	7.558	60	24	7.125	90.0
8	7.995	31.0	12*	8.005	40.0	18*	7.555	60	24	7.245	100.0
8*	7.995	31.0	12	8.042	45.0	18*	7.635	71	24	7.875	105.9
8	8.020	35.0	12*	8.045	45.0	18	8.715	64	24	8.050	121.0
8*	8.020	35.0	12	8.077	50.0	18	8.75	70			
8	8.070	40.0	12*	8.080	50.0	18	8.787	77			
8*	8.070	40.0	12	10.0	53.0	18*	11.035	76			
8	8.110	48.0	12*	9.995	53.0	18*	11.090	86			
8*	8.110	48.0	12	10.014	58.0	18*	11.145	97			
8	8.220	58.0	12*	10.010	58.0	18*	11.200	106			
8*	8.220	58.0	14	5.0	22.0	18*	11.265	119			
8	8.280	67.0	14*	5.0	22.0	18	11.75	96			
8*	8.280	67.0	14	5.025	26.0	21	6.5	44			
10	3.950	11.5	14*	5.025	26.0	21*	6.5	44			
10*	3.960	12.0	14	6.730	30.0	21*	6.530	50			
10	4.0	15.0	14*	6.730	30.0	21*	6.555	57			
10*	4.0	15.0	14	6.75	34.0	21	8.215	55			
10	4.010	17.0	14*	6.745	34.0	21	8.240	62			
10*	4.010	17.0	14	6.770	38.0	21*	8.240	62			
10	4.020	19.0	14*	6.770	38.0	21	8.270	68			
10*	4.020	19.0	14	8.0	43.0	21*	8.270	68			
10	5.75	21.0	14*	7.995	43.0	21	8.295	73			
10*	5.75	22.0	14	8.031	48.0	21*	8.295	73			
10	5.762	25.0	14*	8.030	48.0	21*	8.355	83			
10*	5.770	26.0	14	8.062	53.0	21*	8.420	93			
10	5.799	29.0	14*	8.060	53.0	21	8.962	82			
10*	5.810	30.0	14	10.0	61.0	24	7.005	55			
10	7.960	33.0	14*	9.995	61.0	24*	7.005	55			
10*	7.960	33.0	14	10.035	68.0	24*	7.040	62			
10	7.985	39.0	14	10.035	68.0	24	8.961	68			
10*	7.985	39.0	14	10.072	74.0	24*	8.965	68			
10	8.020	45.0	14*	10.070	74.0	24	8.965	76			
10*	8.020	45.0	14	12.0	78.0	24*	8.990	76			
10	10.0	49.0	14	14.5	87.0	24	9.015	84			
10*	10.0	49.0	14*	10.130	82.0	24*	9.020	84			
10	10.030	54.0	16	5.5	26.0	24	9.065	94			
10*	10.030	54.0	16	5.525	31.0	24*	9.065	94			
10	10.080	60.0	16*	5.525	31.0	-	-	-			
10*	10.080	60.0	16	6.692	36.0	-	-	-			

American Standard

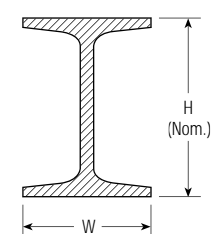

Tapered "S" Beam

Wide Flange

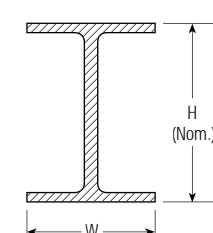

Flat "H" Beam

Quantum

Canada

Toronto, Ontario

51 Worcester Road, Rexdale, Ontario M9W 4K2
Phone: (416) 213-4500 Fax: (416) 213-4510
Order Desk – Fax: (416) 213-4506

Edmonton, Alberta

9720 - 54th Avenue
Edmonton, Alberta T6E 0A9
Phone: (780) 438-5039 Fax: (780) 430-4500

Montreal, Quebec

3501 St. Charles Blvd., Suite 104, Kirkland, Quebec H9H 4S3
Phone: (514) 695-9040 Fax: (514) 695-0963

Vancouver, British Columbia

1200 Cliveden Avenue, Delta, B.C. V3M 6G4
Phone: (604) 523-0803 Fax: (604) 523-0801

Latin America

Ingersoll-Rand Production Equipment Group
730 N.W. 107 Avenue, Suite 300, Miami, Florida 33172-3107
Phone: (305) 559-0500 Fax: (305) 222-0864

Europe, Middle East and Africa

Ingersoll-Rand Material Handling
111, avenue Roger Salengro, 59450 SIN LE NOBLE, France
Phone: (33) 3-27-93-08-08 Fax: (33) 3-27-93-08-00

Asia-Pacific, Ingersoll-Rand Asia-Pacific Inc.

42 Benoi Road, Jurong, 629903, Singapore
Phone: (65) 861 1555 Fax: (65) 861 0317

Australia

Ingersoll-Rand Australia Ltd.
1 Hartnett Drive, Seaford, Vic 3198, Australia
Phone: (61) 3 9554 1642 Fax: (61) 3 9554 1607

Russia Ingersoll-Rand Co.

Kuznetsky Most, 21/5, Entrance 3, Moscow, Russia 103895
Phone: (7) 501 923 9134 Fax: (7) 501 924 4625

Office and distributors in principal cities throughout the world. Contact the nearest Ingersoll-Rand office for the name and address of the distributor in your country or write to: Ingersoll-Rand Company, 1872 Enterprise Drive, Rochester Hills, Michigan, USA 48309



WARNING: Our products are not designed for transporting people or lifting loads over people. It is the user's responsibility to determine the suitability of our products for any particular use and to check compliance with applicable regulations. Before installation, see maintenance and operations manual for additional warnings and precautions.

Call 1-800-347-7047 for distributors in your area.

Visit our web site at:

www.irZimmermann.com

© 2001 Ingersoll-Rand Company

Form No. MHD55226/052501 Printed in U.S.A./30M

 **Ingersoll-Rand.**